

WALL MOUNT - INDOOR UNIT

MODEL OF AIRCONDITIONS

MHWW-18-H-1

PARTS LIST



MULTIAQUA, INC.

2701 S.W. 145 AVENUE, SUITE #220

MIRAMAR, FLORIDA 33027 U.S.A.

Tel: (954) 431-1300 • Fax: (954) 431-1303 • email: support@multiaqua.com

www.multiaqua.com

THIS DRAWING SHALL NOT BE COPIED WITHOUT A PRIOR WRITTEN PERMISSION FROM THIS COMPANY.

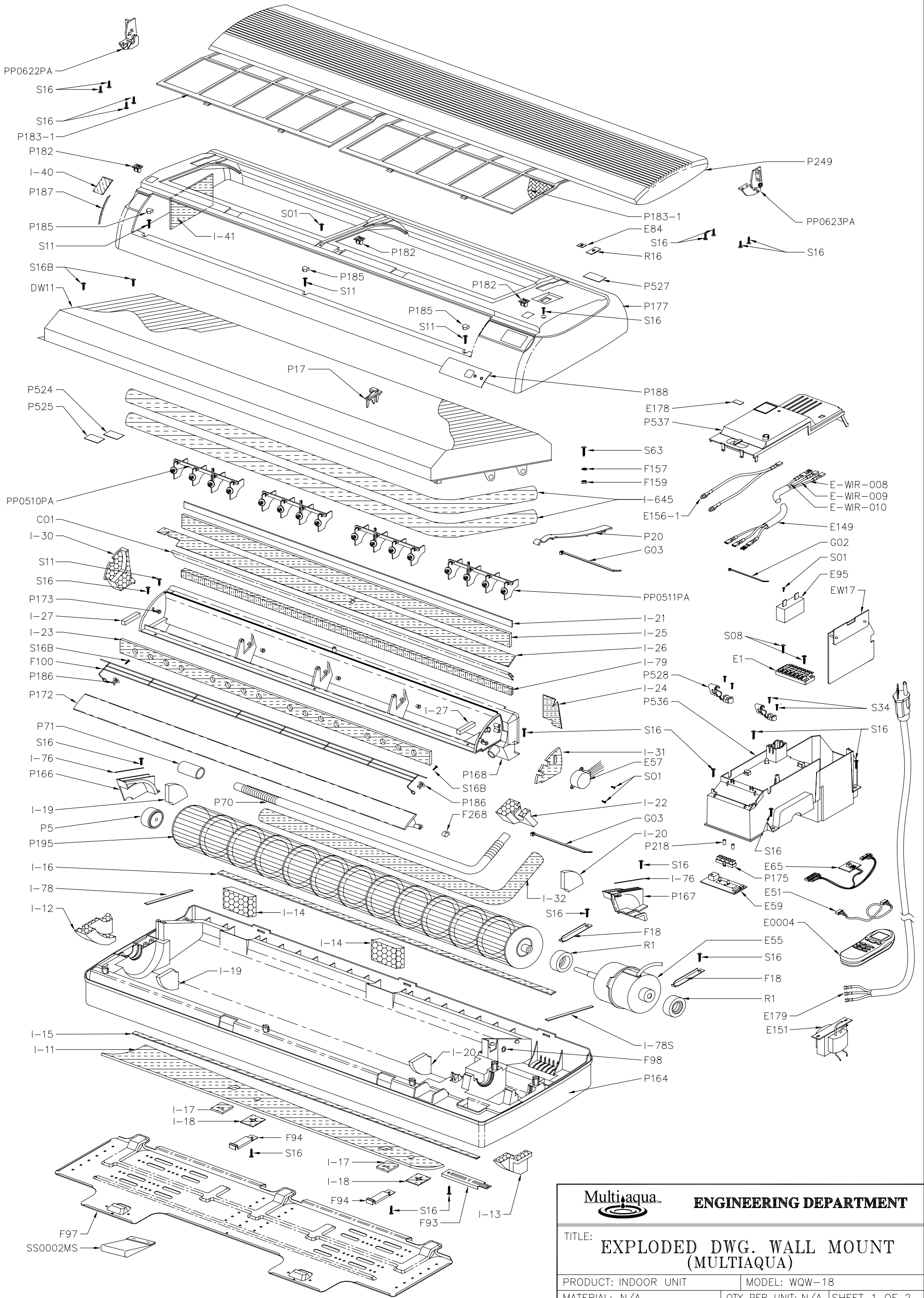

ENGINEERING DEPARTMENT

TITLE: EXPLODED DWG. WALL MOUNT (MULTIAQUA)			
PRODUCT: INDOOR UNIT		MODEL: WQW-18	
MATERIAL: N/A		QTY PER UNIT: N/A	SHEET 1 OF 2
TOLERANCES UNLESS OTHERWISE SPECIFIED		.X ±0.8	.XX ±0.30
		SCALE: NTS	
		HOLE SPACING AND LOCATION ±0.2 NON-CUMULATIVE	
DRWN: R.M.A.	DATE: 13APR01	FN: EXPWQW18H_MUL	
CHKD: F.S.R.	DATE: 13APR01	DWNG NO.: WQ01032B	
APPD: F.S.R.	DATE: 13APR01	PART NO.: N/A	

A	PARTS NO. WERE CHANGE AS PER BOM ISSUED ON 14JAN06	01JUL06	TH.ACH	R.M.A.	F.S.R.
NO.	REVISION	DATE	REV BY	CHK BY	APPD BY

THIS DRAWING SHALL NOT BE COPIED WITHOUT A PRIOR WRITTEN PERMISSION FROM THIS COMPANY.

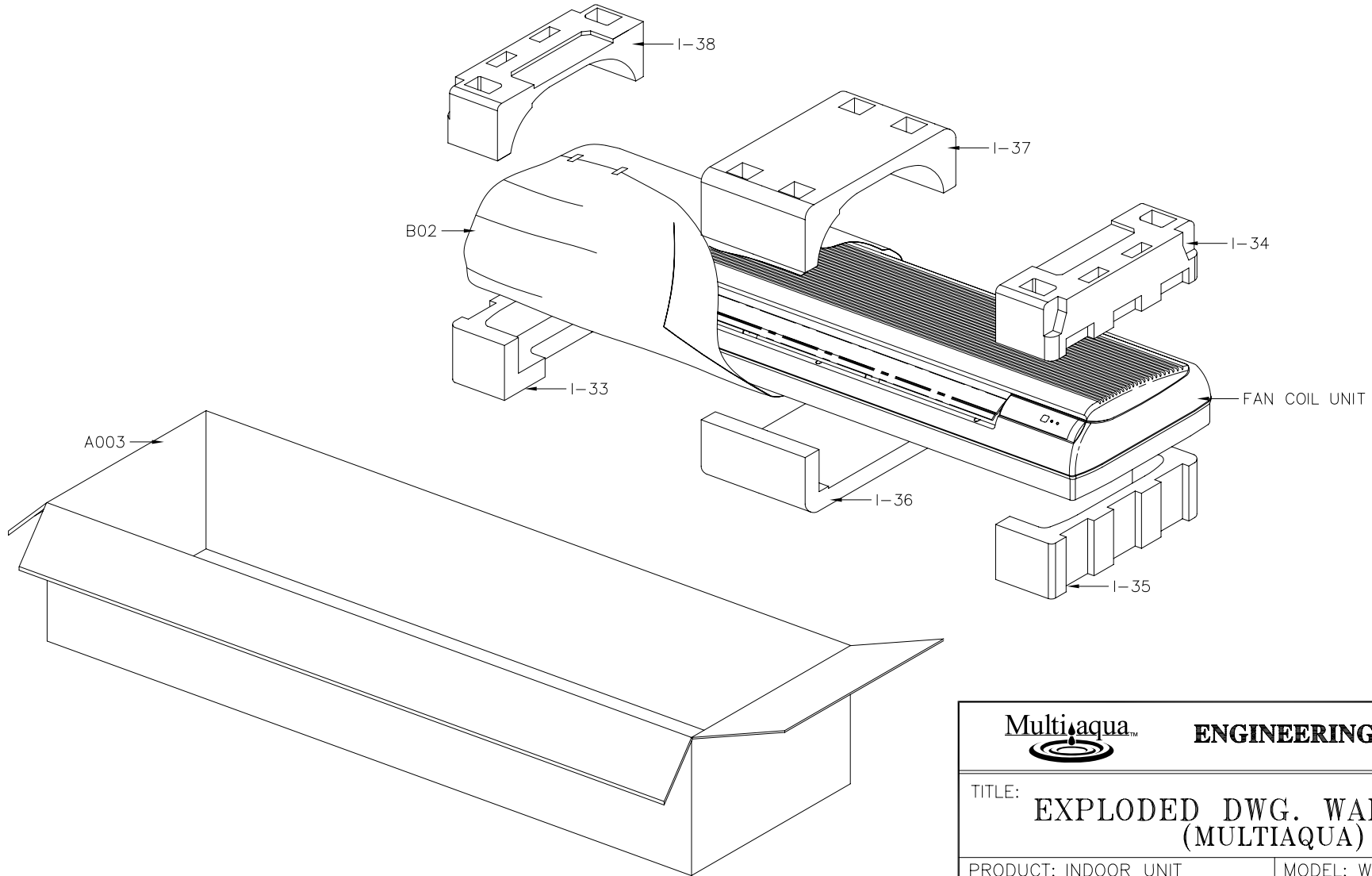

ENGINEERING DEPARTMENT

TITLE: **EXPLODED DWG. WALL MOUNT
(MULTIAQUA)**

PRODUCT: INDOOR UNIT MODEL: WQW-18

MATERIAL: N/A QTY PER UNIT: N/A SHEET 2 OF 2

TOLERANCES UNLESS OTHERWISE SPECIFIED	.X ±0.8	.XX ±0.30	SCALE: NTS
	HOLE SPACING AND LOCATION ±0.2 NON-CUMULATIVE		

DRWN: R.M.A.	DATE: 13APR01	FN: EXPWQW18H_MUL
--------------	---------------	-------------------

CHKD: F.S.R.	DATE: 13APR01	DWNG NO.: WQ01032A
--------------	---------------	--------------------

APPD: F.S.R.	DATE: 13APR01	PART NO.: N/A
--------------	---------------	---------------

A	PARTS NO. WERE CHANGE AS PER BOM ISSUED ON 14JAN06	01JUL06	TH.ACH	R.M.A.	F.S.R.
NO.	REVISION	DATE	REV BY	CHK BY	APPD BY

MHWW-18-H-1 PARTLIST

SEQ.	PART NO.	DESCRIPTION	UM	QTY
NO.	AIRCON			
1	A003	CARTON BOX AMULWQ-18/24 LOGO MULTIAQUA	PC	1
2	B02	AIR BUBBLE 120 x 150 CM.	PC	1
3	C01	GRAY CLOTH WITH PVC	PC	1
4	DW11	WATER COIL : 900 x 254 mm x 2R x 3C x 3/8" Ø PLAIN TUBE x 20 FPI SLIT FINS x FLARE CONNECTOR x 5/8" x 5/8" FLEXIBLE COPPER TUBE Ø 5/8" (ID) x Ø 5/8" (OD)	SET	1
5	E1	TERMINAL BLOCK HP-T3009-3-B1 (6P)	PC	1
6	E51	WIRE HARNESS FOR IR RECEIVER	PC	1
7	E55	MOTOR YDK-35L-4 220/250V 50/60 Hz SPEED MED - LOW - SLOW	PC	1
8	E59	LAMPBOARD	PC	1
9	E57	STEP MOTOR MODEL ST-35	PC	1
10	E65	AUXILLARY SWITCH WITH WIRE HARNESS	PC	1
11	E84	STICKER ON/OFF	PC	1
12	E95	CAPACITOR 2.5 mfd 450VAC	PC	1
13	E149	INSULATION WIRE HARNESS	PC	1
14	E151	TRANSFORMER 24V (SALOM)	PC	1
15	E156-1	GROUND WIRE 13" 16AWG	SET	1
16	E178	CONTROLLER FUSE STICKER	PC	1
17	E179	POWER SUPPLY CORD (SJOW 18AWG/3)	PC	1
18	E0004	REMOTE HANDSET (EPSILON) H/C SCREEN LOGO MULTIAQUA	PC	1
19	EW17	MAIN PCB "MICONTECH" WATER HEAT/COOL	PC	1
20	E-WIR-008	ELECTRICAL WIRE - RED 15" 18AWG. W/QUICK CONNECTOR	PC	1
21	E-WIR-009	ELECTRICAL WIRE - WHITE 15" 18AWG. W/QUICK CONNECTOR	PC	1
22	E-WIR-010	ELECTRICAL WIRE - YELLOW 15" 18AWG. W/QUICK CONNECTOR	PC	1
23	F18	BRACKET MOTOR	PCS	2
24	F93	PIPING CLAMP # 1	PC	1
25	F94	PIPING CLAMP # 2	PCS	2
26	F97	MOUNTING BRACKET	PC	1
27	F98	FLAT WASHER Ø 7.0 mm x Ø 15 x 1.5 mm	PC	1
28	F100	WIRE GUARD	PC	1
29	F157	STAR WASHER	PCS	3
30	F159	HEX. NUT M4 x 0.07 (BRASS)	PCS	2
31	F268	METAL SLEEVE FOR HORIZONTAL LOUVER WQ-18/24/30	PC	1
32	G02	TIE WIRE 4"	PCS	3
33	G03	TIE WIRE 8"	PCS	2
34	I-11	INSUL. BASE PAN - BACK	PC	1

35	I-12	INSUL. FOAM BASE PAN BACK - L	PC	1
36	I-13	INSUL. FOAM BASE PAN BACK - R	PC	1
37	I-14	SEAL BLOCK	PCS	2
38	I-15	INSUL. BASE PAN RAIL	PC	1
39	I-16	INSUL. BASE PAN TOP	PC	1
40	I-17	INSUL. BACK SEAL # 1	PCS	2
41	I-18	INSUL. BACK SEAL # 2	PCS	2
42	I-19	INSUL. BLOWER LH	PCS	2
43	I-20	INSUL. BLOWER RH	PCS	2
44	I-21	INSUL. DRAIN PAN STRIP-BACK	PC	1
45	I-22	INSUL. FOAM INSERT-DRAIN PAN-R	PC	1
46	I-23	INSUL. DEFLECTOR	PC	1
47	I-24	INSUL. DRAIN SIDE	PC	1
48	I-25	INSUL. DRAIN PAN TOP	PC	1
49	I-26	INSUL. DRAIN PAN STRIP	PC	1
50	I-27	INSUL. DRAIN PAN AIR OUTLET	PCS	2
51	I-30	INSUL. FOAM DRAIN PAN LEFT	PC	1
52	I-31	INSUL. DRAIN PAN RIGHT	PC	1
53	I-32	INSUL. DRAIN HOSE	PC	1
54	I-33	PACKAGING FOAM BOTTOM LH	PC	1
55	I-34	PACKAGING FOAM TOP RH	PC	1
56	I-35	PACKAGING FOAM BOTTOM RH	PC	1
57	I-36	PACKAGING FOAM BOTTOM - MIDDLE	PC	1
58	I-37	PACKAGING FOAM TOP - MIDDLE	PC	1
59	I-38	PACKAGING FOAM TOP LH	PC	1
60	I-40	INSUL. FRAME FRONT-LEFT	PC	1
61	I-41	INSUL. FRAME SIDE - L	PC	1
62	I-76	INSUL. BASE PAN SUPPORT - BTM. R AND L	PCS	2
63	I-78	INSUL. BASE PAN SUPPORT - TOP L	PC	1
64	I-78S	INSUL. BASE PAN SUPPORT - TOP R	PC	1
65	I-79	INSUL. DRAN PAN FRONT	PC	1
66	I-645	INSULATION TUBE 22 mm ID x 6 mm THK x1150 mm L (AEROFLEX)	PCS	2
67	P5	NYLON PIVOT W/RUBBER	PC	1
68	P17	SENSOR HOLDER-WHITE	PC	1
69	P20	STRAP EVAP - WHITE	PC	1
70	P70	DRAIN HOSE	PC	1
71	P71	DRAIN HOSE CONNECTOR	PC	1
72	P164	BASE PAN WQ-18/24/30	PC	1
73	P166	EVAP SUPPORT - L	PC	1

74	P167	EVAP SUPPORT - R	PC	1
75	P168	DRAIN PAN	PC	1
76	P172	HORIZONTAL LOUVER	PC	1
77	P173	BUSHING	PCS	4
78	P175	LIGHT COVER	PC	1
79	P177	FRAME GRILL	PC	1
80	P182	LOCK	PCS	3
81	P183-1	AIR FILTER (GREEN)	PCS	2
82	P185	SCREW COVER	PCS	3
83	P186	PLASTIC SCREW RIVET F386	PCS	2
84	P187	LOUVER STICKER	PC	1
85	P188	DISPLAY MEMBRANE 18/24/30	PC	1
86	P195	BLOWER Ø 102 x 900 mm	PC	1
87	P218	LAMP SLEEVE (KNT TUBE C)	PC	2
88	P249	DECO PANEL SCREEN LOGO MULTIAQUA	PC	1
89	P524	"WATER IN" STICKER	PCS	2
90	P525	"WATER OUT" STICKER	PCS	2
91	P527	STICKER WARNING	PC	1
92	P528	WIRE CLAMP	PCS	2
93	P536	CONTROL BOX	PC	1
94	P537	CONTROL BOX COVER	PC	1
95	PP0510PA	DEFLECTOR ASY - LH WQ-SERIES 18-30	SET	2
96	PP0511PA	DEFLECTOR ASY - RH WQ-SERIES 18-30	SET	2
97	PP0622PA	HINGE LH ASSY WQ - SERIES	SET	1
98	PP0623PA	HINGE RH ASSY WQ - SERIES	SET	1
99	R1	RUBBER MOTOR	PCS	2
100	R16	RUBBER CAP	PC	1
101	S01	SCREW 4 x 10 mm.	PCS	8
102	S08	SCREW 4 x 19 mm. (6 x 3/4") POINTED, NICKEL	PCS	2
103	S11	SCREW 8 x 3/4" (POINTED)	PCS	4
104	S16	SCREW 4 x 12 mm.	PCS	23
105	S16B	SCREW 4 x 12 mm. (BLACK)	PCS	4
106	S34	SCREW 4 x 12 mm. (8x1/2") (POINTED)	PCS	4
107	S63	SCREW 4 x 12 mm. (BRASS)	PC	1
108	E156-1	GROUND WIRE 13" 16AWG	SET	1
109	SS0002MS	SCREW FOR BRACKET UNIT MOUNT WQ-18/24/30	SET	1