



CWA2 Chilled Water Fan Coil With or Without Electric Heat

2-Pipe Heat / Cool Fan Coil 18,000 - 60,000 BTUH

CWA2 NOMENCLATURE BREAKDOWN

2-Pipe Heat/Cool with Electric Heat Multiposition Fan Coil

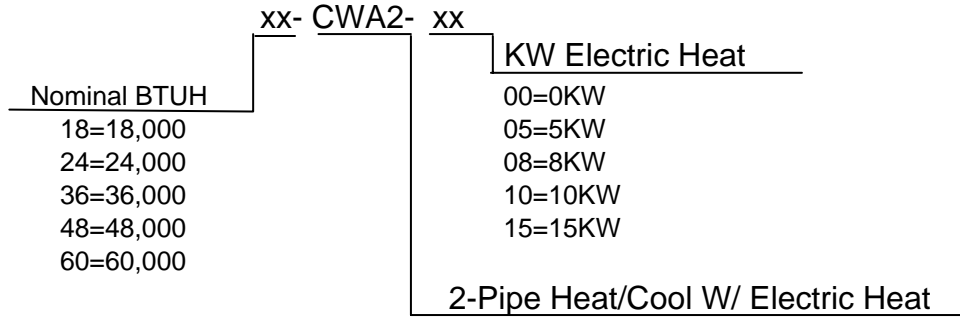

Note:

The CWA2 is only available in 208/230-1-60

Available Model Numbers				
18CWA2-00	18CWA2-05	18CWA2-08	18CWA2-10	18CWA2-15
24CWA2-00	24CWA2-05	18CWA2-08	18CWA2-10	18CWA2-15
36CWA2-00	36CWA2-05	18CWA2-08	18CWA2-10	18CWA2-15
48CWA2-00	48CWA2-05	18CWA2-08	18CWA2-10	18CWA2-15
60CWA2-00	60CWA2-05	18CWA2-08	18CWA2-10	18CWA2-15

HVAC Guide Specifications

Chilled/ Hot Water W/Electric Heat Multi-Position Fan Coil
2-Pipe

Nominal Size:

18,000 – 60,000 BTUH

MultiAqua Model Number:

18CWA2

24CWA2

36CWA2

48CWA2

60CWA2

Part 1-General

1.01 System Description

MultiAqua Chilled Water Fan Coils are manufactured with heavy gauge galvanized steel to resist corrosion.

1.02 Quality Assurance

- A. Certified in accordance with U.L. Standard 95, latest version (U.S.A.)
- B. Manufactured in a facility registered to ISO 9002, Manufacturing Quality Standard.
- C. Fully load tested at the factory.
- D. Damage resistant packaging.

1.03 Delivery, Storage and Handling

- A. Packaged and readied for shipment from the factory.
- B. Controls shall be capable of withstanding 150°F storage temperatures in the control compartment.
- C. Stored and handled per manufacturer's recommendations.

Part 2-Product

2.01 Equipment

- A. General:
 - 1. Unit shall be a factory assembled and tested multi-position chilled/ hot water with electric heat fan coil.
 - 2. Shall be assembled with high quality.
 - 3. Contained with the unit shall be all factory wiring, piping, associated controls and special accessories required prior to start up.
- B. Unit Cabinet:
 - 1. Composed of heavy gauge galvanized steel casing with baked polyester powder.
 - 2. Shall be internally insulated to insure quiet operation.
 - 3. Cabinet shall be capable of being installed in a vertical or horizontal position.
- C. Fan Motors:
 - 1. Shall be available in 208/230-1-60 vac.
 - 1. Fan motors shall be three speed, direct drive, and PSC type.
 - 2. Internal overload protected.
- D. Blower Wheels:
 - 1. Blower wheels are forward curved and dynamically balanced.
- E. Water Coil:
 - 1. Manufactured with water coils containing 3/8" copper tubing mechanically bonded to aluminum fins.
 - 2. Coils shall be factory tested to 350 psig.
 - 3. Coil shall contain manual air bleed port.
- F. Drain Pan:
 - 1. Drain pan shall be molded with high impact polymers.
 - 2. Pan shall contain a primary and secondary drain connection.
 - 3. Pan shall be capable of draining in the vertical and horizontal positions without changing the pan configuration.

G. Filters:

1. Unit shall contain a filter door for easy access to the filter.
2. A filter track shall be provided.
3. Unit shall come supplied with a 1" throwaway filter.

H. Electric Heaters:

1. Unit shall be capable of incorporating an electric heat package.
2. Electric heaters shall be of the open wire type.
3. Electric heat packages shall contain non-fused breakers, sequencers and safeties.

Part 3-Controls and Safeties**3.01 Controls**

- A. Fan coils shall be completely factory wired and tested.
- B. Unit shall include a terminal block that is capable of incorporating a 24 vac thermostat.

3.02 Safeties:

- A. Fan coil shall contain a non reusable fuse on the secondary voltage side of the transformer.
- B. Electric heat package shall contain non-fusible breakers and high temperature limits.

Part 4-Operating Characteristics:**4.01 Electrical Requirements**

- A. Electrical shall include a terminal block.
- B. Electrical power supply shall be rated to withstand 120°F operating ambient temperatures.

CWA2 Product Specifications

Physical Data									
Model Number	Height (in)	Length (in)	Depth (in)	Weight (lbs)	Cooling Rows FPI	Copper Diameter (in)	Water Inlet (in)	Water Outlet (in)	Drain (in)
18CWA2	39.75	17.50	21.00	118.00	4-14	3/8	1/2	1/2	3/4
24CWA2	39.75	17.50	21.00	118.00	4-14	3/8	1/2	1/2	3/4
36CWA2	39.75	17.50	21.00	145.00	4-14	3/8	3/4	3/4	3/4
48CWA2	49.75	21.50	25.00	170.00	4-14	3/8	3/4	3/4	3/4
60CWA2	49.75	21.50	25.00	180.00	4-14	3/8	3/4	3/4	3/4

Electrical Data						
Model Number	Nominal CFM	Volts/Phase/Hertz	Motor HP	Full Load Ampacity	Fuse or HACR Circuit Breaker Per Circuit	
					Minimum Amps	Maximum Amps
18CWA2	600	208/230-1-60	1/4	1.7	2.13	4
24CWA2	800		1/3	2.8	3.50	7
36CWA2	1200		1/3	2.8	3.50	7
48CWA2	1600		1/3	3.2	4.00	8
60CWA2	2000		3/4	4.8	6.00	11

Model Number	Nominal CFM	KW Electric Heat		Minimum Ampacity		Maximum Breaker	
		208V	240V	208V	240V	208V	240V
18CWA2-XX	600	0	0	2.1	1.9	15	15
		5	3.8	29	25	30	25
		8	6	44	39	45	40
		10	7.5	55	48	60	50
24CWA2-XX	900	0	0	2.1	1.9	15	15
		5	3.8	29	25	30	25
		8	6	44	39	45	40
		10	7.5	55	48	60	50
36CWA2-XX	1200	0	0	3.5	3.4	15	15
		5	3.8	30	27	30	30
		8	6	46	40	50	40
		10	7.5	56	49	60	50
		15	11.3	56/26	49/23	60/30	50/30
48CWA2-XX	1600	0	0	4	3.9	15	15
		5	3.8	30	27	30	35
		8	6	46	41	50	45
		10	7.5	57	50	60	50
		15	11.3	53/30	46/27	60/30	50/30
		20	15	57/53	50/46	60/60	50/50
60CWA2-XX	2000	0	0	6	5.9	15	15
		5	3.8	32	29	35	30
		8	6	48	42	50	45
		10	7.5	59	52	60	60
		15	11.3	53/32	46/29	60/35	50/30
		20	15	59/53	52/46	60/60	60/50

These specifications are subject to change without notice.

CWA2 Chilled Water Performance Data

18CWA2-XX COOLING CAPACITIES					
NOMINAL CFM	EWT (°F)	GPM	WPD	ENTERING AIR TEMPERATURE	
				80° D.B. / 67° W.B.	
400	42	3.0	1.8	TC	12.2
				SC	9.2
				APD	0.1
		4.5	3.9	TC	13.4
				SC	10.1
				APD	0.1
		6.0	6.8	TC	14.2
				SC	10.6
				APD	0.1

18CWA2-XX COOLING CAPACITIES					
NOMINAL CFM	EWT (°F)	GPM	WPD	ENTERING AIR TEMPERATURE	
				80° D.B. / 67° W.B.	
600	42	3.5	2.4	TC	16.6
				SC	12.5
				APD	0.18
		5.0	4.8	TC	18.1
				SC	13.6
				APD	0.18
		6.5	7.9	TC	19.1
				SC	14.4
				APD	0.18

18CWA2-XX COOLING CAPACITIES					
NOMINAL CFM	EWT (°F)	GPM	WPD	ENTERING AIR TEMPERATURE	
				80° D.B. / 67° W.B.	
400	45	3.0	1.8	TC	11.5
				SC	9.2
				APD	0.1
		4.5	3.9	TC	12.5
				SC	10.0
				APD	0.1
		6.0	6.8	TC	13.2
				SC	10.5
				APD	0.1

18CWA2-XX COOLING CAPACITIES					
NOMINAL CFM	EWT (°F)	GPM	WPD	ENTERING AIR TEMPERATURE	
				80° D.B. / 67° W.B.	
600	45	3.5	2.4	TC	15.7
				SC	12.6
				APD	0.18
		5.0	4.8	TC	17.0
				SC	13.6
				APD	0.18
		6.5	7.9	TC	17.9
				SC	14.3
				APD	0.18

These specifications are subject to change without notice.

CWA2 Chilled Water Performance Data

24CWA2-XX COOLING CAPACITIES					
NOMINAL CFM	EWT (°F)	GPM	WPD	ENTERING AIR TEMPERATURE	
				80° D.B. / 67° W.B.	
600	42	3.0	2.2	TC	16.5
				SC	12.4
				APD	0.14
		4.5	4.7	TC	18.4
				SC	13.8
				APD	0.14
		6.0	8.2	TC	19.7
				SC	14.7
				APD	0.14

24CWA2-XX COOLING CAPACITIES					
NOMINAL CFM	EWT (°F)	GPM	WPD	ENTERING AIR TEMPERATURE	
				80° D.B. / 67° W.B.	
800	42	3.5	2.9	TC	20.9
				SC	15.7
				APD	0.21
		5.0	5.8	TC	22.9
				SC	17.2
				APD	0.21
		6.5	9.6	TC	24.4
				SC	18.3
				APD	0.21

24CWA2-XX COOLING CAPACITIES					
NOMINAL CFM	EWT (°F)	GPM	WPD	ENTERING AIR TEMPERATURE	
				80° D.B. / 67° W.B.	
600	45	3.0	2.2	TC	15.7
				SC	12.7
				APD	0.14
		4.5	4.7	TC	17.3
				SC	13.8
				APD	0.14
		6.0	8.2	TC	18.3
				SC	14.6
				APD	0.14

24CWA2-XX COOLING CAPACITIES					
NOMINAL CFM	EWT (°F)	GPM	WPD	ENTERING AIR TEMPERATURE	
				80° D.B. / 67° W.B.	
800	45	3.5	2.9	TC	19.8
				SC	15.8
				APD	0.21
		5.0	5.8	TC	21.6
				SC	17.3
				APD	0.21
		6.5	9.6	TC	22.9
				SC	18.3
				APD	0.21

These specifications are subject to change without notice.

CWA2 Chilled Water Performance Data

36CWA2-XX COOLING CAPACITIES					
NOMINAL CFM	EWT (°F)	GPM	WPD	ENTERING AIR TEMPERATURE	
				80° D.B. / 67° W.B.	
1000	42	4.0	2.1	TC	26.0
				SC	19.5
				APD	0.2
		6.0	4.6	TC	29.0
				SC	21.8
				APD	0.2
		8.0	8.1	TC	31.0
				SC	23.2
				APD	0.2

36CWA2-XX COOLING CAPACITIES					
NOMINAL CFM	EWT (°F)	GPM	WPD	ENTERING AIR TEMPERATURE	
				80° D.B. / 67° W.B.	
1200	42	5.0	3.3	TC	31.2
				SC	23.3
				APD	0.3
		6.5	5.4	TC	33.3
				SC	25.0
				APD	0.3
		8.0	8.1	TC	35.0
				SC	26.3
				APD	0.3

36CWA2-XX COOLING CAPACITIES					
NOMINAL CFM	EWT (°F)	GPM	WPD	ENTERING AIR TEMPERATURE	
				80° D.B. / 67° W.B.	
1000	45	4.0	2.1	TC	24.8
				SC	19.8
				APD	0.23
		6.0	4.6	TC	27.3
				SC	21.8
				APD	0.23
		8.0	8.1	TC	29.0
				SC	23.2
				APD	0.23

36CWA2-XX COOLING CAPACITIES					
NOMINAL CFM	EWT (°F)	GPM	WPD	ENTERING AIR TEMPERATURE	
				80° D.B. / 67° W.B.	
1200	45	5.0	3.3	TC	29.6
				SC	23.7
				APD	0.28
		6.5	5.4	TC	31.5
				SC	25.2
				APD	0.28
		8.0	8.1	TC	31.9
				SC	25.5
				APD	0.28

These specifications are subject to change without notice.

CWA2 Chilled Water Performance Data

48CWA2-XX COOLING CAPACITIES					
NOMINAL CFM	EWT (°F)	GPM	WPD	ENTERING AIR TEMPERATURE	
				80° D.B. / 67° W.B.	
1400	42	4.5	1.2	TC	33.4
				SC	25.0
				APD	0.24
		6.0	2.2	TC	36.3
				SC	27.2
				APD	0.24
		7.5	3.3	TC	38.5
				SC	28.9
				APD	0.24

48CWA2-XX COOLING CAPACITIES					
NOMINAL CFM	EWT (°F)	GPM	WPD	ENTERING AIR TEMPERATURE	
				80° D.B. / 67° W.B.	
1600	42	6.0	2.2	TC	39.5
				SC	29.6
				APD	0.25
		8.0	3.8	TC	42.7
				SC	32.0
				APD	0.25
		10.0	5.8	TC	45.1
				SC	33.8
				APD	0.25

48CWA2-XX COOLING CAPACITIES					
NOMINAL CFM	EWT (°F)	GPM	WPD	ENTERING AIR TEMPERATURE	
				80° D.B. / 67° W.B.	
1400	45	4.5	1.2	TC	32.0
				SC	25.6
				APD	0.24
		6.0	2.2	TC	34.5
				SC	27.6
				APD	0.24
		7.5	3.3	TC	36.4
				SC	29.1
				APD	0.24

48CWA2-XX COOLING CAPACITIES					
NOMINAL CFM	EWT (°F)	GPM	WPD	ENTERING AIR TEMPERATURE	
				80° D.B. / 67° W.B.	
1600	45	6.0	2.2	TC	37.7
				SC	30.2
				APD	0.25
		8.0	3.8	TC	40.5
				SC	32.4
				APD	0.25
		10.0	5.8	TC	42.6
				SC	34.1
				APD	0.25

These specifications are subject to change without notice.

CWA2 Chilled Water Performance Data

60CWA2-XX COOLING CAPACITIES					
NOMINAL CFM	EWT (°F)	GPM	WPD	ENTERING AIR TEMPERATURE	
				80° D.B. / 67° W.B.	
1600	42	6.5	2.8	TC	42.5
				SC	31.9
				APD	0.19
		8.5	4.6	TC	45.6
				SC	34.2
				APD	0.19
		10.5	6.9	TC	48.1
				SC	36.1
				APD	0.19

60CWA2-XX COOLING CAPACITIES					
NOMINAL CFM	EWT (°F)	GPM	WPD	ENTERING AIR TEMPERATURE	
				80° D.B. / 67° W.B.	
2000	42	7.0	3.2	TC	50.0
				SC	37.5
				APD	0.27
		10.0	6.3	TC	55.1
				SC	41.3
				APD	0.27
		13.0	10.5	TC	58.7
				SC	44.0
				APD	0.27

60CWA2-XX COOLING CAPACITIES					
NOMINAL CFM	EWT (°F)	GPM	WPD	ENTERING AIR TEMPERATURE	
				80° D.B. / 67° W.B.	
1600	45	6.5	2.8	TC	40.4
				SC	32.3
				APD	0.19
		8.5	4.6	TC	43.1
				SC	34.5
				APD	0.19
		10.5	6.9	TC	45.2
				SC	36.2
				APD	0.19

60CWA2-XX COOLING CAPACITIES					
NOMINAL CFM	EWT (°F)	GPM	WPD	ENTERING AIR TEMPERATURE	
				80° D.B. / 67° W.B.	
2000	45	7.0	3.2	TC	47.7
				SC	36.2
				APD	0.27
		10.0	6.3	TC	52.1
				SC	41.7
				APD	0.27
		13.0	10.5	TC	55.2
				SC	44.2
				APD	0.27

These specifications are subject to change without notice.

CWA2 Hot Water Performance Data

18CWA2-00 HEATING CAPACITIES									
ENTERING AIR (°F)	CFM	GPM	WPD	APD	140°	150°	160°	170°	180°
					65	400	3.0	1.6	0.08
4.5	3.5	31058	34314	37570			41560	45540	
6.0	6.0	31658	34979	38300			42360	46420	

18CWA2-00 HEATING CAPACITIES									
ENTERING AIR (°F)	CFM	GPM	WPD	APD	140°	150°	160°	170°	180°
					65	600	3.5	2.2	0.15
5.0	4.3	43416	47948	52480			58100	63660	
6.5	7.1	44664	49337	54010			59750	65490	

24CWA2-00 HEATING CAPACITIES									
ENTERING AIR (°F)	CFM	GPM	WPD	APD	140°	150°	160°	170°	180°
					65	600	3.0	2.2	0.14
4.5	4.7	44330	48955	53580			59270	65000	
6.0	8.2	45762	50566	55370			61240	67100	

24CWA2-00 HEATING CAPACITIES									
ENTERING AIR (°F)	CFM	GPM	WPD	APD	140°	150°	160°	170°	180°
					65	800	3.5	2.9	0.21
5.0	5.8	55781	61590	67400			74600	81790	
6.5	9.6	57970	64050	70130			77590	85000	

These specifications are subject to change without notice.

CWA2 Hot Water Performance Data

36CWA2-00 HEATING CAPACITIES									
ENTERING AIR (°F)	CFM	GPM	WPD	APD	140°	150°	160°	170°	180°
					65	1000	4.0	2.1	0.23
6.0	4.6	68302	75401	82500			83100	91100	
8.0	8.1	71508	78954	86400			95600	104850	

36CWA2-00 HEATING CAPACITIES									
ENTERING AIR (°F)	CFM	GPM	WPD	APD	140°	150°	160°	170°	180°
					65	1200	5.0	3.3	0.28
6.5	5.4	78566	86733	94900			105000	115200	
8.0	8.1	81635	90119	98600			109200	119700	

48CWA2-00 HEATING CAPACITIES									
ENTERING AIR (°F)	CFM	GPM	WPD	APD	140°	150°	160°	170°	180°
					65	1400	4.5	1.2	0.24
6.0	2.2	88660	97830	107000			118500	130000	
7.5	3.3	93529	103244	112960			125000	137140	

48CWA2-00 HEATING CAPACITIES									
ENTERING AIR (°F)	CFM	GPM	WPD	APD	140°	150°	160°	170°	180°
					65	1600	6.0	2.2	0.25
8.0	3.8	103596	114348	125100			138500	151900	
10.0	5.8	108411	119680	130950			144945	158960	

These specifications are subject to change without notice.

CWA2 Hot Water Performance Data

60CWA2-00 HEATING CAPACITIES									
ENTERING AIR (°F)	CFM	GPM	WPD	APD	140°	150°	160°	170°	180°
					65	1600	6.5	2.8	0.19
8.5	4.6	109120	120510	131900			145950	160000	
10.5	6.9	113451	131204	137160			151750	166350	

60CWA2-00 HEATING CAPACITIES									
ENTERING AIR (°F)	CFM	GPM	WPD	APD	140°	150°	160°	170°	180°
					65	2000	7.0	3.2	0.27
10.0	6.3	131285	144967	158650			175580	192500	
13.0	10.5	138037	152443	166850			184600	202400	

These specifications are subject to change without notice.

CWA2 CFM and Glycol Adjustments

Model Number	Motor Speed	CFM vs. ESP				
		0.1	0.2	0.3	0.4	0.5
18CWA-XX	High	650	600	550	490	420
	Medium	550	500	440	380	310
	Low	500	460	330	-	-
24CWA-XX	High	950	900	850	790	720
	Medium	850	800	740	680	610
	Low	700	660	610	550	480
36CWA-XX	High	1250	1200	1120	1060	1000
	Medium	1070	1020	970	920	860
	Low	900	870	840	790	720
48CWA-XX	High	1850	1700	1650	1500	1410
	Medium	1750	1650	1450	1330	1180
	Low	1150	1060	1000	920	810
60CWA-XX	High	2160	2100	2000	1940	1880
	Medium	2110	1980	1810	1750	1650
	Low	2000	1860	1670	1340	1200

Example:

24CWA2 @ 0.20" ESP produces 900 cfm.

Locate 900 cfm (for the 24CWA2) on the Capacity Adjustment Factors on page 247. (TC = 1.05 & SC = 1.05)

Multiply the stated chilled water capacity for the 24CWA2 on page 239 or the hot water capacity on page 243 by the adjustment factors to achieve the capacity adjustment.

Propylene Glycol & GPM Adjustment Factors			
Ambient Temp	Propylene Glycol %	Capacity Reduction	GPM Adjustment = 100% Capacity
26° F	10%	x 0.99	x 1.01
20° F	20%	x 0.98	x 1.03
8° F	30%	x 0.98	x 1.07
-5° F	40%	x 0.97	x 1.11
-28° F	50%	x 0.96	x 1.16

Example:

30% Propylene Glycol Solution.

System capacity x 0.98

GPM x 1.07

These specifications are subject to change without notice.

CWA2 Capacity Adjustment Factors

CWA2 CAPACITY CORRECTION FACTORS						
MODEL #	18CWA2		24CWA2		36CWA2	
CFM	TC	SC	TC	SC	TC	SC
310	0.74	0.71				
325	0.75	0.72				
350	0.77	0.74				
375	0.79	0.77				
400	0.82	0.79				
425	0.84	0.81				
450	0.86	0.84				
475	0.88	0.86	0.76	0.75		
500	0.91	0.88	0.78	0.77		
525	0.93	0.92	0.80	0.79		
550	0.96	0.95	0.82	0.81		
575	0.98	0.97	0.84	0.83		
600	1.00	1.00	0.86	0.85		
625	1.02	1.03	0.87	0.84		
650	1.04	1.05	0.89	0.86		
675			0.90	0.88		
700			0.91	0.91		
720			0.93	0.92	0.61	0.59
725			0.94	0.93	0.62	0.60
750			0.96	0.96	0.64	0.62
775			0.98	0.98	0.66	0.64
800			1.00	1.00	0.67	0.65
825			1.01	1.01	0.69	0.67
850			1.02	1.03	0.71	0.70
875			1.04	1.04	0.73	0.72
900			1.05	1.05	0.75	0.74
925			1.05	1.07	0.77	0.76
950			1.05	1.08	0.79	0.78
975					0.82	0.81
1000					0.85	0.84
1025					0.87	0.86
1050					0.89	0.88
1075					0.92	0.91
1100					0.94	0.93
1125					0.96	0.95
1150					0.97	0.97
1175					0.98	0.98
1200					1.00	1.00
1225					1.02	1.03
1250					1.04	1.05

These specifications are subject to change without notice.

CWA2 Capacity Adjustment Factors

CWA2 CAPACITY CORRECTION FACTORS				
MODEL #	48CWA2		60CWA2	
CFM	TC	SC	TC	SC
800	0.40	0.39		
825	0.42	0.40		
875	0.46	0.44		
925	0.48	0.46		
950	0.50	0.48		
975	0.52	0.50		
1000	0.54	0.52		
1025	0.55	0.53		
1050	0.56	0.54		
1075	0.58	0.56		
1100	0.60	0.58		
1125	0.62	0.60		
1175	0.66	0.64		
1200	0.67	0.65	0.40	0.39
1225	0.69	0.67	0.42	0.40
1250	0.71	0.70	0.44	0.42
1275	0.73	0.72	0.46	0.44
1300	0.75	0.74	0.47	0.45
1325	0.77	0.76	0.48	0.46
1350	0.79	0.78	0.50	0.48
1375	0.82	0.81	0.52	0.50
1400	0.85	0.84	0.54	0.52
1425	0.87	0.86	0.55	0.53
1450	0.89	0.88	0.56	0.54
1475	0.92	0.91	0.58	0.56
1500	0.94	0.93	0.60	0.58
1525	0.96	0.95	0.62	0.60
1550	0.97	0.97	0.64	0.62
1575	0.98	0.98	0.66	0.64
1600	1.00	1.00	0.67	0.65
1625	1.02	1.03	0.69	0.67
1650	1.04	1.05	0.71	0.70
1675	1.06	1.07	0.73	0.72
1725	1.08	1.09	0.77	0.76
1750	1.09	1.10	0.79	0.78
1775	1.10	1.11	0.82	0.81
1800	1.11	1.12	0.85	0.84
1825	1.13	1.14	0.87	0.86
1850	1.14	1.15	0.89	0.88
1875			0.92	0.91
1900			0.94	0.93
1925			0.96	0.95
1950			0.97	0.97
1975			0.98	0.98
2000			1.00	1.00
2025			1.02	1.03
2050			1.04	1.05
2075			1.06	1.07
2100			1.07	1.08
2125			1.08	1.09
2150			1.09	1.10
2160			1.10	1.11

These specifications are subject to change without notice.

INSTALLATION and OPERATION MANUAL



CWA2
Multi^aaqua™



INSTALLATION & OPERATING MANUAL

CWA2 Chilled Water Fan Coil with Electric Heat
18,000 – 60,000 BTUH

----- CAUTION -----

Care must be taken when handling sheet metal. Sheet metal parts have sharp edges and could cause injury.

GENERAL

Read the entire contents of this manual before beginning installation. Multiaqua assumes no responsibility for equipment installed contradictory to any code requirement or installation instructions.

The components of this fan coil have been inspected at the factory and readied for shipment. Upon receiving the shipment a visual inspection of the packaging must be performed.

If any damage to the packaging is discovered, an inspection of the components must be performed and noted on the delivery documents. If component damage is found a damage claim must be filed by the receiving party against the delivery party immediately.

This product is designed and manufactured to permit installation in accordance with national codes. It is the installer's responsibility to install the product in accordance with national codes and/or prevailing local codes and regulations.

Care must be taken to ensure the structural integrity of the supporting members, clearances and provisions for servicing, power supply, coil connections and/or condensate removal. Before the installation ensure the structural strength of the supporting members is sufficient. See figure 1 for hanging weights of the fan coils.

This unit is designed to be installed in a

vertical or horizontal configuration. See figure 2 for fan coil only dimensions. The coil hand of connection is field reversible.

FAN COIL MODEL NUMBER	APPROXIMATED WEIGHTS (LBS)
18CWA2	118
24CWA2	118
36CWA2	145
48CWA2	170
60CWA2	180

Figure 1



INSTALLATION & OPERATING MANUAL

CWA2 Chilled Water Fan Coil with Electric Heat
18,000 – 60,000 BTUH

Physical Dimensions (in)					
Model Number	A	B	C	D	E
18CWA2	17.50	21.00	39.75	12.50	16.00
24CWA2	17.50	21.00	39.75	12.50	16.00
36CWA2	17.50	21.00	39.75	12.50	16.00
48CWA2	21.50	25.00	49.75	17.25	19.50
60CWA2	21.50	25.00	49.75	17.25	19.50

Figure 2

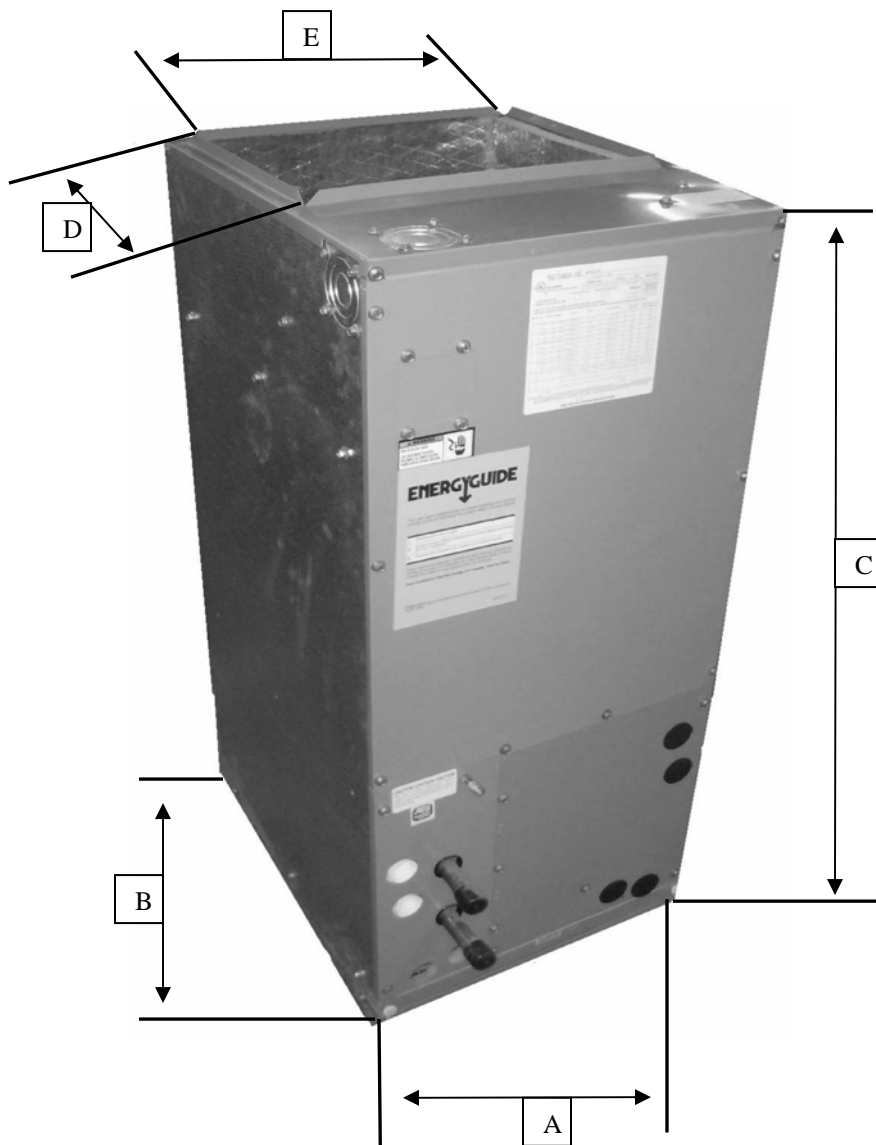



INSTALLATION & OPERATING MANUAL

CWA2 Chilled Water Fan Coil with Electric Heat
18,000 – 60,000 BTUH

----- CAUTION -----

Care must be taken when handling sheet metal. Sheet metal parts have sharp edges and could cause injury.

INSTRUCTIONS FOR INSTALLING FAN COIL

The CWA2 is a chilled water fan coil with electric heat designed for multi-position applications in closets, attics or basements. They are field convertible to horizontal applications without the need for additional parts. Unit is not suitable for down flow applications.

Figure 3 & 4

CONVERTING FAN COIL TO RIGHT HAND DISCHARGE

The CWA2 fan coil comes shipped from the factory assembled with a left hand air discharge configuration.

1. To convert the fan coil to right hand discharge remove the three front panels.
2. Remove the three screws from the coil mounting brackets and pull entire coil assembly out of the fan coil.

Figure 5



Figure 3



Figure 4

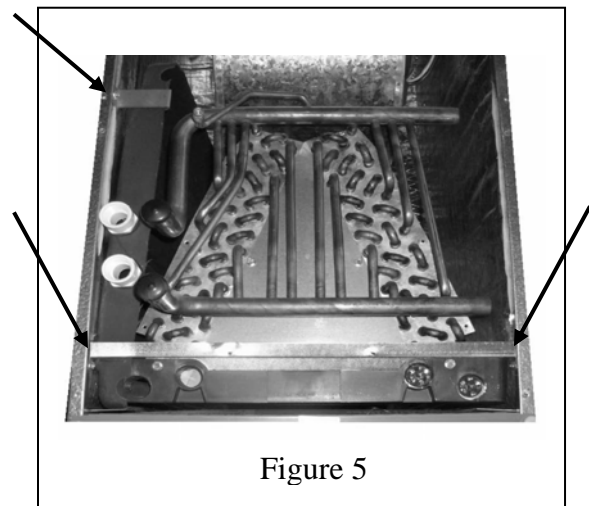

Figure 5



INSTALLATION & OPERATING MANUAL

CWA2 Chilled Water Fan Coil with Electric Heat
18,000 – 60,000 BTUH

3. Remove the horizontal drain pan from the coil and re-install it on the other side.

Figure 6

4. Ensure the coil mounting brackets are secure in order to avoid coil misplacement inside the cabinet. Check coil slope to make sure that the drain pan slopes toward the drain outlet. An incorrectly installed coil could result in damages to the fan coil and property.

5. Re-install the three front panels previously removed in step one.

6. The unit shall be suitable for 0" clearance to combustible materials. Sufficient clearance must be provided at the front of the fan coil to allow access for maintenance and servicing.

7. The fan coil comes with one primary and one secondary condensate drain connection per configuration. Ensure when connecting the field installed condensate drain lines, the lower of the two fan coil drain connections is piped into the buildings condensate removal method.

Figure 7 & 8

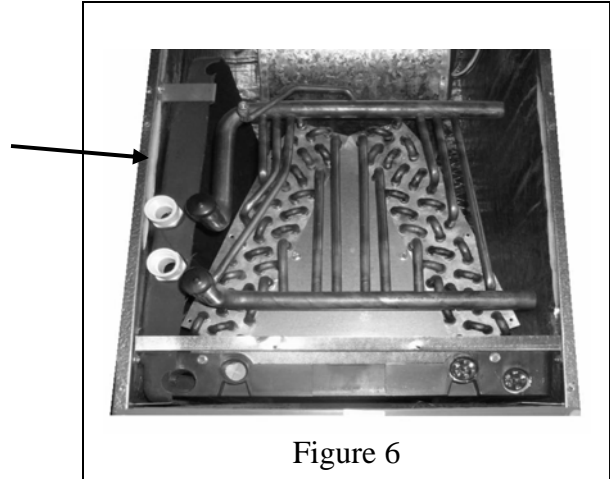

Figure 6

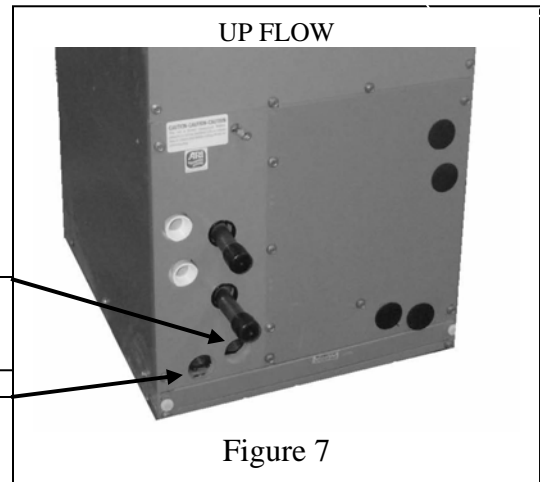

Figure 7

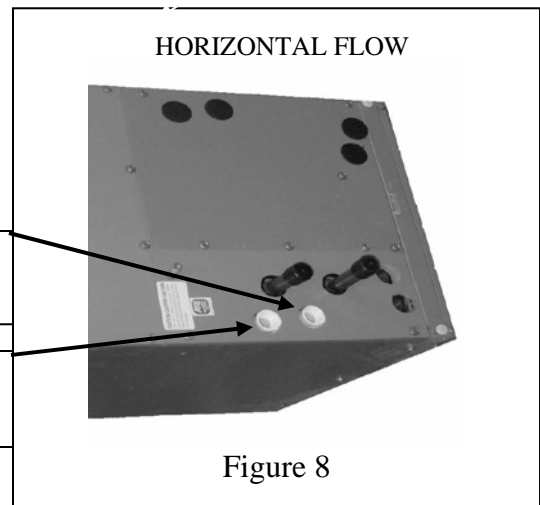

Figure 8



INSTALLATION & OPERATING MANUAL

CWA2 Chilled Water Fan Coil with Electric Heat
18,000 – 60,000 BTUH

8. All duct work must be installed per local and national codes. The return air duct and the return air opening provided in the fan coil must have the same area.

Figure 9 & 10

ELECTRICAL

All wiring must comply with local and national codes. High and low voltage terminal blocks are provided. An electrical plug is provided for the field installation of electric heat packages. Knockouts are provided in the cabinet for field wiring of the electrical. See page 255 for electric heat package installation instructions.

- A = High Voltage terminal block.
- B = Electric Heat Package Connection Plug.
- C = Low Voltage Terminal Block.

Figure 11

CONTROLS

A 24 vac transformer, fan relay and electric heat sequencer are provided inside cabinet. All supplied controls are wired onto the low voltage terminal block.

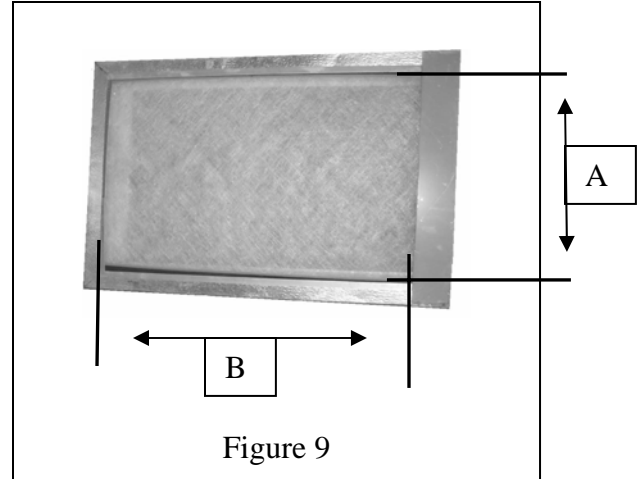

Figure 9

CWA2 Inlet Air Dimensions		
	A	B
18CWA2	15	17.5
24CWA2	15	17.5
36CWA2	15	17.5
48CWA2	19.25	22.25
60CWA2	19.25	22.25

Figure 10

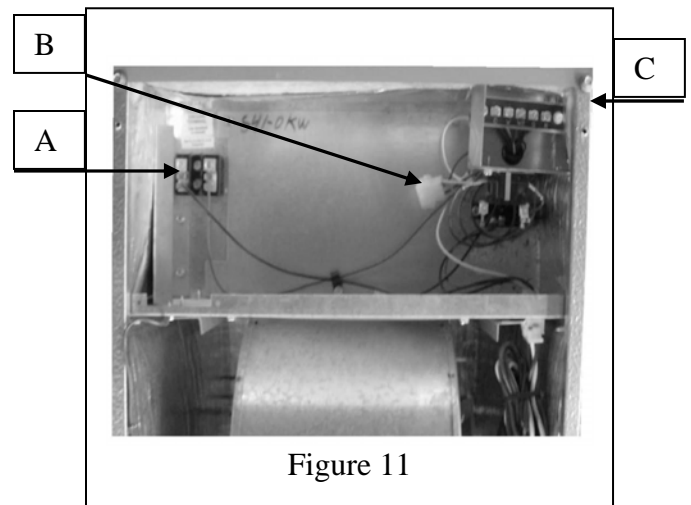

Figure 11



INSTALLATION & OPERATING MANUAL

CWA2 Chilled Water Fan Coil with Electric Heat
18,000 – 60,000 BTUH

INSTALLATION INSTRUCTION FOR B41HK-05, B41HK-08, B41HK-10, B41HK-15, B41HK- 15, B51HK-05, B51HK-08, B51HK-10, B51HK-15 and B51HK-20

ELECTRIC HEATER SLIDE IN MODULE

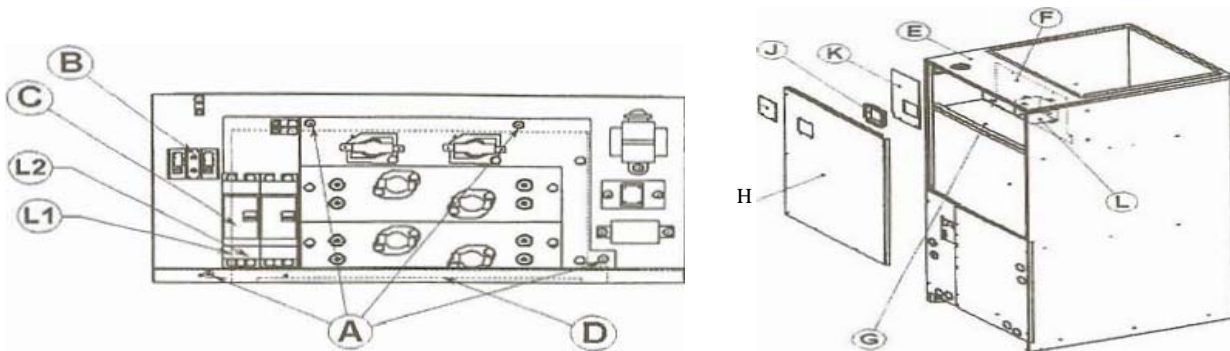

TO INSTALL THE SLIDE IN MODULE:

1. Disconnect the unit from the power supply. Make sure no electricity is connected to the unit.
2. Remove the door (H) from the unit.
3. Remove the terminal box (L1)(L2) which is attached to the top panel (E) with two screws and clear the way for the slide in electric heat package.
4. Remove the cover plate (F) from the heater deck.
5. Unplug red and black wires from the terminal block (B) and move them to the right side of cabinet to allow installation of the electric heat package.
6. Raise the electric heat package enough to clear the mounting tab. (D) Slide the electric heat package halfway through. Plug the two wires (which were unplugged in step 5) to the left circuit breaker or provided .25" insulated male terminals (C), black wire on left connection (L1) red wire on right connection (L2).
7. Slide the electric heat package in, secure with screws (A).
8. Complete field line voltage wiring.
9. Attach the breaker cover (K) to heater deck (G) with two blunt screws. Remove the plate (I) from the door (H), replace with breaker flange (J) and attach to the same plate with four screws.
10. Secure terminal box (L) with two screws to the top panel (E), connect 6-pin plugs, and complete low voltage field wiring.
11. Replace door (H) and check unit operation.

Note: Breaker cover (K) and breaker flange (J) are shipped with electric heat package.



INSTALLATION & OPERATING MANUAL

CWA2 Chilled Water Fan Coil with Electric Heat
18,000 – 60,000 BTUH

PIPING

9. This fan coil is supplied with one water coil that can be used for chilled and or hot water. The coil has one dedicated inlet and outlet. Ensure that both lines are insulated according to local and national building codes.

Figure 12

10. Condensate drains must be installed with at least .25" of slope per foot away from the fan coil. Since the drain pan is located on the suction side of the blower a minimum trap of 1.5" must be installed in the drain line for proper drainage.

ROUTINE CHECK UP AND SERVICE

This product is designed to provide many years of dependable, trouble free comfort when properly maintained. Proper maintenance will consist of routine filter cleanings/changes, bi-annual check ups that include but not limited to filter inspections, electric heater inspections /cleaning of the internal electrical and heat transfer components by a qualified service technician. Failure to provide periodic check ups and cleaning can result in excessive operating cost and/or equipment failure.

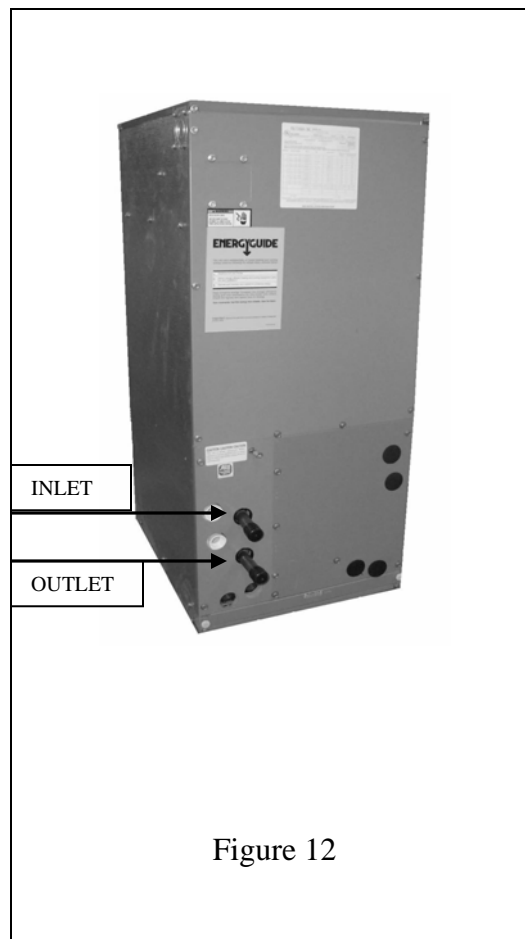
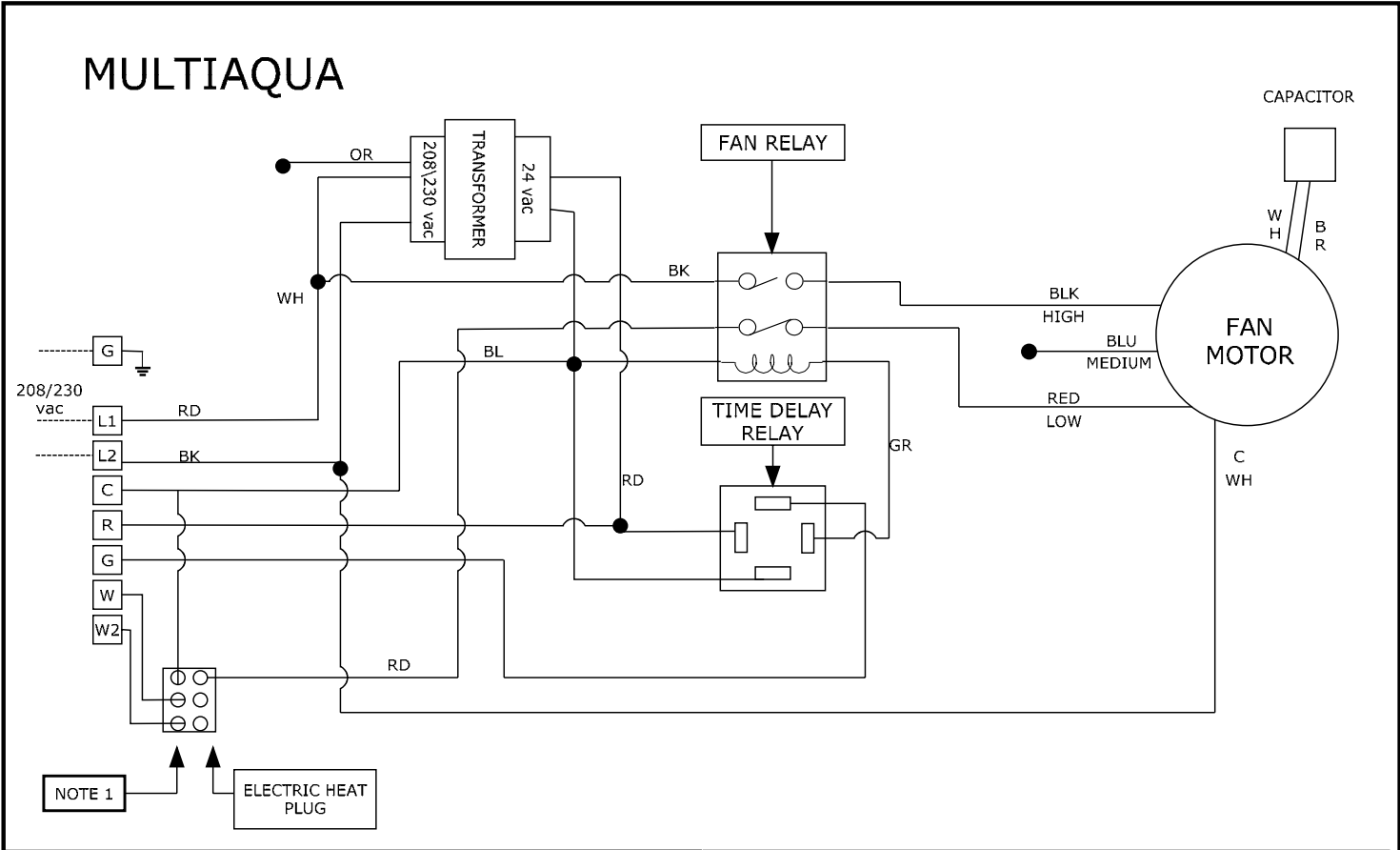

Figure 12

CWA2-00 Wiring Diagram

120-1-60



TITLE CWA2-00 WIRING DIAGRAM		LEGEND:	NOTES:
AUTHOR	kjg	—— FACTORY WIRING	1. NOT USED WITHOUT ELECTRIC HEAT
DATE	06-07-07	----- FIELD WIRING	
REVISION	0607300020		
	SHEET 1 OF 1		

CWA2 CERTIFIED DRAWING

CWA2 Certified Drawing
 Drawing # 0907400078

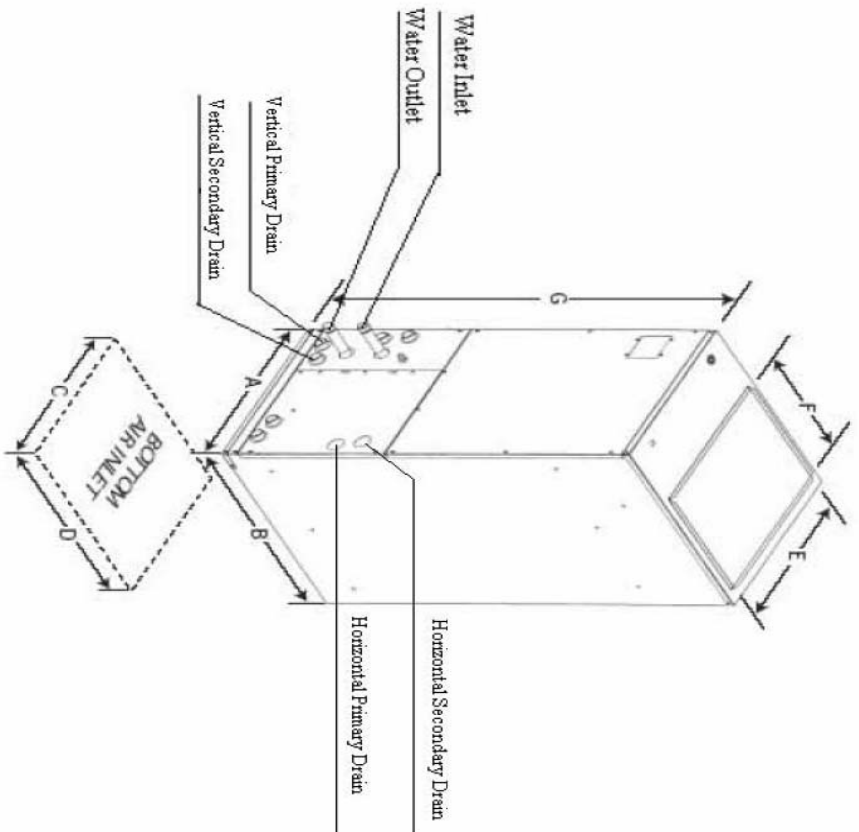

Model No.	A	B	C	D	E	F	G
18 & 24CWA2-XX	17 1/2	21	15	17 1/2	16	12 3/8	39 1/4
36CWA2-XX	17 1/2	21	15	17 1/2	16	12 3/8	39 1/4
48 & 60CWA2-XX	21 1/2	25	19 1/4	22 1/4	19 3/8	17 1/4	49 1/4

Note: "-XX" indicates electric heat (KW) size.