

MCCX Direct Expansion Ceiling Concealed

Direct Expansion Fan Coil 48,000 - 60,000 BTUH

MCCX NOMENCLATURE BREAKDOWN

Direct Expansion Ceiling Concealed Fan Coil

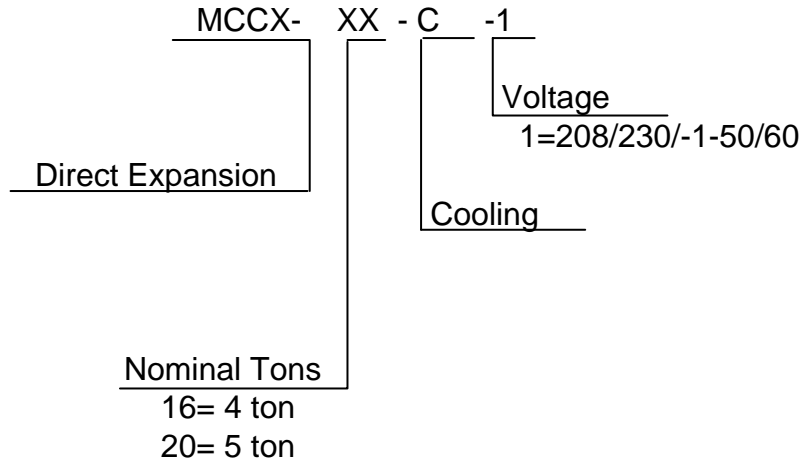

| Available Model Numbers |
|----------------------------|
| MCCX-16-C-1 MCCX-20-C-1 |

HVAC Guide Specifications

Direct Expansion Fan Coil

Nominal Size:

48,000 – 60,000 BTUH

MultiAqua Model Number:

MCCX16

MCCX20

Part 1-General

1.01 System Description

MultiAqua Direct Expansion Fan Coils are manufactured with heavy gauge galvanized steel to resist corrosion.

1.02 Quality Assurance

- A. Certified in accordance with U.L. Standard 95, latest version (U.S.A.)
- B. Manufactured in a facility registered to ISO 9002, Manufacturing Quality Standard.
- C. Fully load tested at the factory.
- D. Damage resistant packaging.

1.03 Delivery, Storage and Handling

- A. Packaged and readied for shipment from the factory.
- B. Controls shall be capable of withstanding 150°F storage temperatures in the control compartment.
- C. Stored and handled per manufacturer's recommendations.

Part 2-Product

2.01 Equipment

- A. General:
 1. Unit shall be a factory assembled and tested direct expansion fan coil.
 2. Shall be assembled with heavy gauge galvanized steel.
 3. Contained with the unit shall be all factory wiring, piping, associated controls and special accessories required prior to start up.
- B. Unit Cabinet:
 1. Composed of heavy gauge galvanized steel casing with a baked polyester powder.
 2. Shall be internally insulated to insure quiet operation.
- C. Fan Motors:
 1. Shall be available in 208/230-1-50/60 vac.
 1. Fan motors shall be three speed, direct drive, and PSC type.
 2. Totally enclosed.
 3. Internal overload protected.
- D. Blower Wheels:
 1. Blower wheels are forward curved and dynamically balanced.
- E. DX Coil:
 1. Manufactured with 3/8" copper rifled tubing mechanically bonded to aluminum fins.
 2. Contain a thermal expansion valve.
 3. Coils shall be factory tested to 350 psig.
 4. Coils shall be capable of being field converted from right to left hand connection.
- F. Drain Pan:
 1. All drain pans shall be coated on both the interior and exterior with baked polyester powder to resist corrosion.
 2. The exterior of all drain pans shall be insulated with closed cell to prevent condensation.
 3. Pans shall contain a left and right hand primary sloped drain connection as well as a sloped right hand secondary drain connection.

Part 3-Controls and Safeties**3.01 Controls**

- A. Fan coils shall be completely factory wired and tested.
- B. All components shall be wired to an internal terminal block to allow for a field installed thermostat and or fan speed control.
- C. Controls shall include the following components.
 - 1. 24vac transformer.
 - 2. Fan relays.
 - 3. Optional thermostats.

3.02 Safeties:

- A. Fan coil shall contain a non reusable fuse on the secondary voltage side of the transformer.

Part 4-Operating Characteristics:**4.01 Electrical Requirements**

- A. Primary electrical power supply shall enter the unit at a single location.
- B. Electrical power supply shall be rated to withstand 120°F operating ambient temperatures.
- D. Control and high voltage points shall be accessed through terminal block.

MCCX Product Specifications & Capacity

| Physical Data | | | | | | | | | |
|---------------|-------------|------------|------------|--------------|---------------|----------------------|------------------|-------------------|------------|
| Model Number | Height (in) | Width (in) | Depth (in) | Weight (lbs) | Coil Rows FPI | Copper Diameter (in) | Liquid Line (in) | Suction Line (in) | Drain (in) |
| MCCX16 | 13.78 | 48.50 | 20.00 | 68.34 | 3-14 | 3/8 | 3/8 | 3/4 | 1/2 |
| MCCX20 | 13.78 | 56.10 | 20.00 | 72.80 | 3-14 | 3/8 | 3/8 | 3/4 | 1/2 |

| Electrical Data | | | | | | |
|-----------------|-------------|---------------------|----------|--------------------|--|--------------|
| Model Number | Nominal CFM | Volts/ Phase/ Hertz | Motor HP | Full Load Ampacity | Fuse or HACR Circuit Breaker Per Circuit | |
| | | | | | Minimum Amps | Maximum Amps |
| MCCX-16-C-1 | 1600 | 208/230-1-50/60 | 1/2 | 2.72 | 3.40 | 7 |
| MCCX-20-C-1 | 2000 | 208/230-1-50/60 | 1/2 | 2.72 | 3.40 | 7 |

| Performance Data | | |
|------------------|-------------|------------------|
| Model Number | Nominal CFM | Cooling Capacity |
| MCCX-16-C-1 | 1600 | 48,000 |
| MCCW-20-C-1 | 2000 | 58,000 |

| Nominal CFM vs. External Static Pressure Table | | | | | | |
|--|----------|------|------|------|------|------|
| Model Number | Hi Speed | | | | | |
| | 0.05 | 0.10 | 0.15 | 0.20 | 0.25 | 0.30 |
| MCCX-16 | 1435 | 1420 | 1390 | 1355 | 1316 | 1281 |
| MCCX-20 | 1435 | 1415 | 1400 | 1363 | 1325 | 1290 |

These specifications are subject to change without notice.

INSTALLATION and OPERATION MANUAL

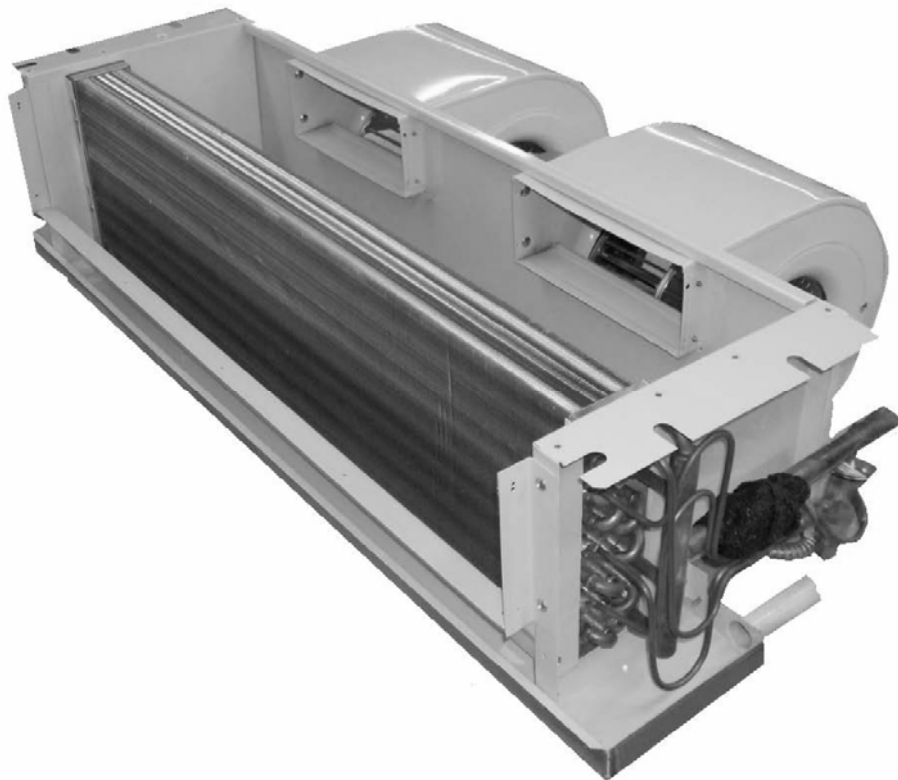

MCCX





INSTALLATION & OPERATING MANUAL

MCCX Fan Coils 4 & 5 Tons

----- CAUTION -----

Care must be taken when handling sheet metal. Sheet metal parts have sharp edges and could cause injury.

GENERAL

Read the entire contents of this manual before beginning installation. Multiaqua assumes no responsibility for equipment installed contradictory to any code requirement or installation instructions.

The components of this fan coil have been inspected at the factory and readied for shipment. Upon receiving the shipment a visual inspection of the packaging must be performed.

If any damage to the packaging is discovered, an inspection of the components must be performed and noted on the delivery documents. If component damage is found a damage claim must be filed by the receiving party against the delivery party immediately.

This product is designed and manufactured to permit installation in accordance with national codes. It is the installer's responsibility to install the product in accordance with national codes and/or prevailing local codes and regulations.

Care must be taken to ensure the structural integrity of the supporting members, clearances and provisions for servicing, power supply, coil connections and/or condensate removal. Before the installation ensure the structural strength of the supporting members is sufficient. See figure 1 for hanging weights of the fan coils.

This unit is designed to be installed in a

horizontal configuration only. See figure 2 for fan coil dimensions.

The coil hand of connection is field reversible. See figures 4-6 for converting the coil hand of connection.

| FAN COIL MODEL NUMBER | APPROXIMATED WEIGHTS (LBS) |
|--------------------------|-------------------------------|
| MCCX16 | 68.34 |
| MCCX20 | 72.80 |

Figure 1



INSTALLATION & OPERATING INSTRUCTIONS

MCCX Fan Coils 4 & 5 Tons

| FAN COIL DIMENSIONS (in) | | | | | | |
|--------------------------|-------|-------|-------|-------|------|-------|
| Fan Coil Model Number | A | B | C | D | E | F |
| MCCX16 | 48.39 | 43.86 | 42.20 | 13.74 | 9.49 | 19.80 |
| MCCX20 | 56.38 | 51.85 | 42.20 | 13.74 | 9.49 | 19.80 |

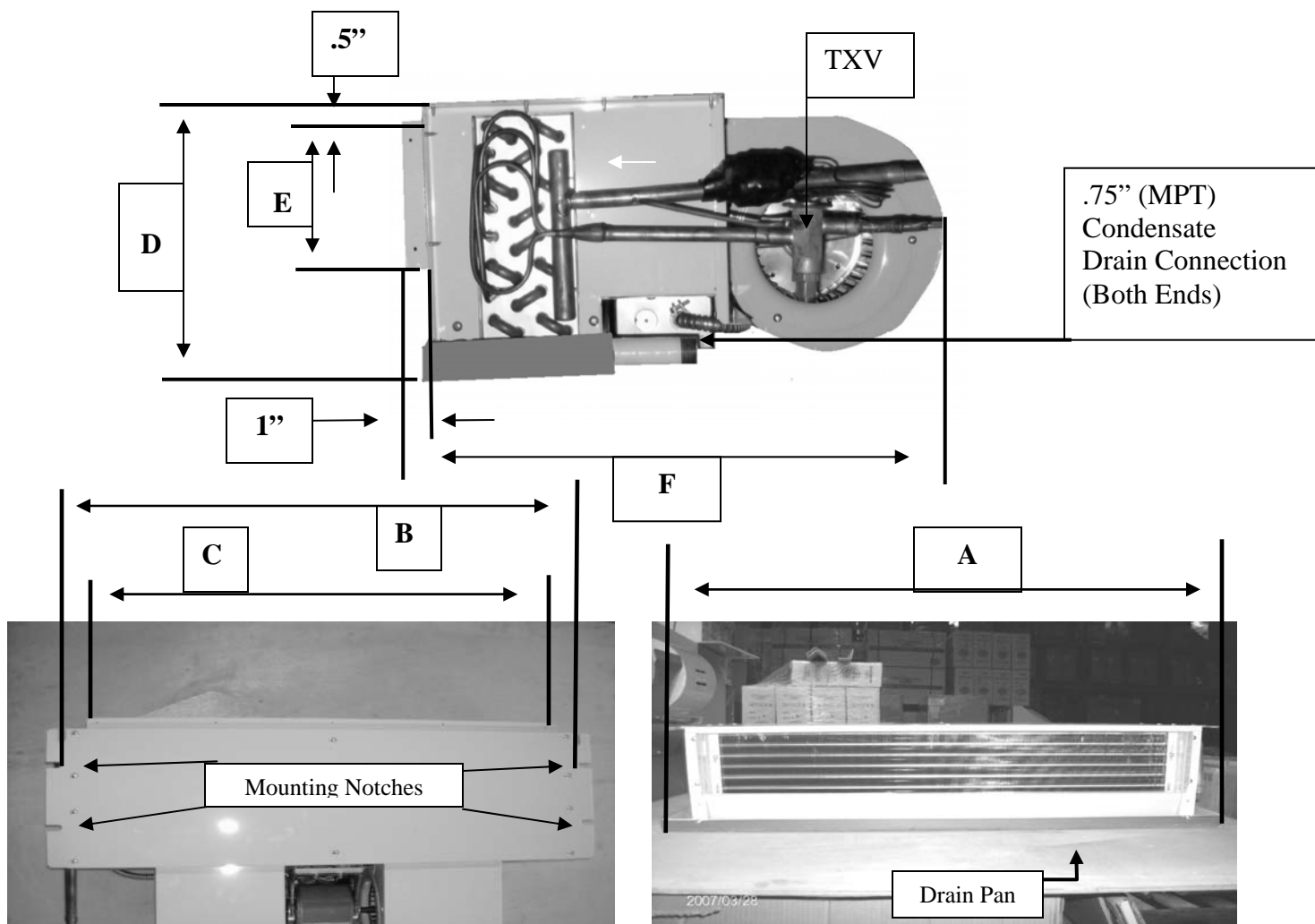

Figure 2

----- CAUTION -----

Care must be taken when handling sheet metal. Sheet metal parts have sharp edges and could cause injury.

INSTRUCTIONS FOR CONVERTING COIL HAND OF CONNECTION

1. Remove the eleven screws that attach the top to the fan coil assembly and remove the top. This will allow you to access the electric heaters.

Figure 3

2. Remove the eight screws that hold the coil into the fan coil frame assembly. Four screws per side.

Figure 4

3 Slide the coil out of the fan coil frame assembly toward the coil supply and return line connections. Ensure that care is taken when removing and inserting the coil not to damage the coil fins. Insert the coil into the fan coil frame assembly from the other end and reverse procedures 3 & 4 to reassemble the fan coil.

Figure 5

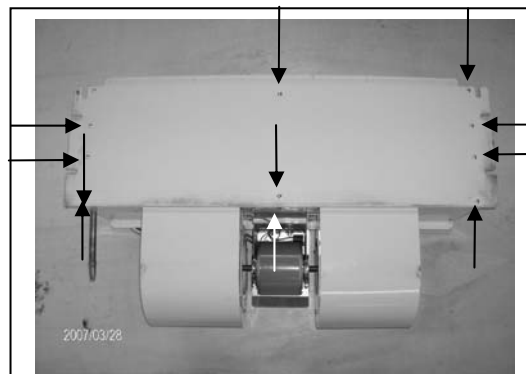

Figure 3

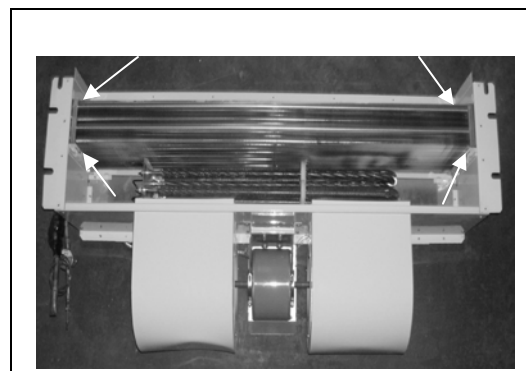

Figure 4

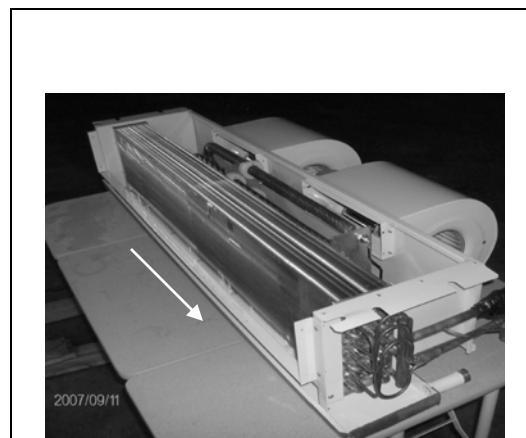

Figure 5

ELECTRICAL & CONDENSATE DRAIN

4. There are four termination points for the electrical wiring. There are two on each side of the electrical box. See page 316 for electrical drawing. Wiring must be installed according to prevailing codes and regulations.

The fan coil unit has one condensate drain connection on either side of the drain pan for either left or right hand drain connection. The opposite drain connection not being used must be capped off by the installing contractor. The middle drain connection is the safety condensate drain connection. Ensure that all condensate drain lines have at least one quarter of an inch of fall per foot for proper drainage.

Figure 6

DIRECT EXPANSION COIL CONNECTIONS

5. The fan coil unit comes with a Thermal Expansion Valve installed on the DX coil. Ensure that the suction line is insulated all the way to the coil header and the liquid line is insulated from the TXV to the distributor.

Figure 7

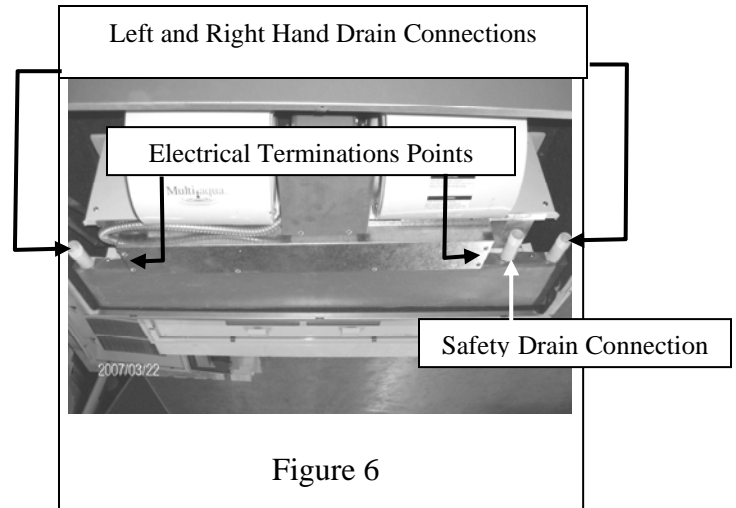

Figure 6

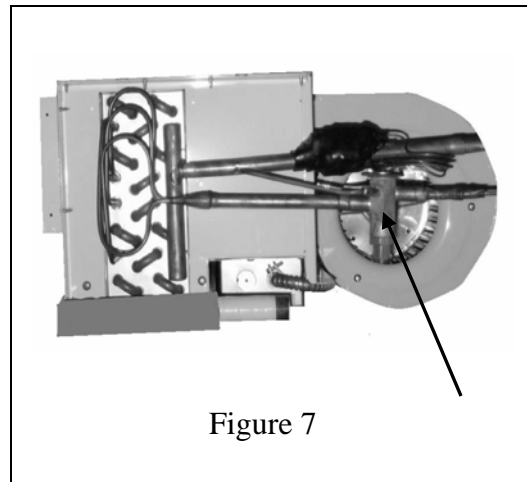

Figure 7



INSTALLATION & OPERATION MANUAL

MCCX Fan Coils 4 & 5 Tons

MAINTENANCE

1. Air Filter(s):

Filters are an essential part of the quality of air that is provided to the occupants. Never operate HVAC equipment without filters. Filters help remove dust and unwanted particles from the air stream, helping to keep the space clean. They also keep this debris from collecting on the heat transfer surfaces of the unit thus maintaining optimum equipment efficiency and performance. These filters will be located either in the unit or upstream from the unit in the return air ductwork. Filters must be inspected, cleaned and/or changed routinely. This routine maintenance procedure will allow the unit to continually operate as designed, reduce service expenses and extend equipment/component life.

2. Fuses and/or Circuit Breakers:

This unit must be connected to the buildings electric service in accordance with local/national electrical codes and regulations. These electrical connections will include over current protection in the form of fuses or circuit breakers. Have your contractor identify/label the circuits and the location of them so that you may be in a position to make inspections

and/or replacements in the event the unit fails to operate or is being serviced. If fuses are used, ensure that the replacement fuses are of the same size and type as the ones you are replacing. It is a good idea to keep replacement fuses of the appropriate size and type on hand.

3. Routine Check Up and Service:

This product is designed to provide many years of dependable, trouble free comfort when properly maintained. Proper maintenance will consist of routine filter cleanings/changes, bi-annual check ups that include but not limited to filter inspections, electric heater inspections /cleaning of the internal electrical and heat transfer components by a qualified service technician. Failure to provide periodic check ups and cleaning can result in excessive operating cost and/or equipment failure.

MHCCX Without Electric Heat Wiring Diagram

208/230-1-50/60

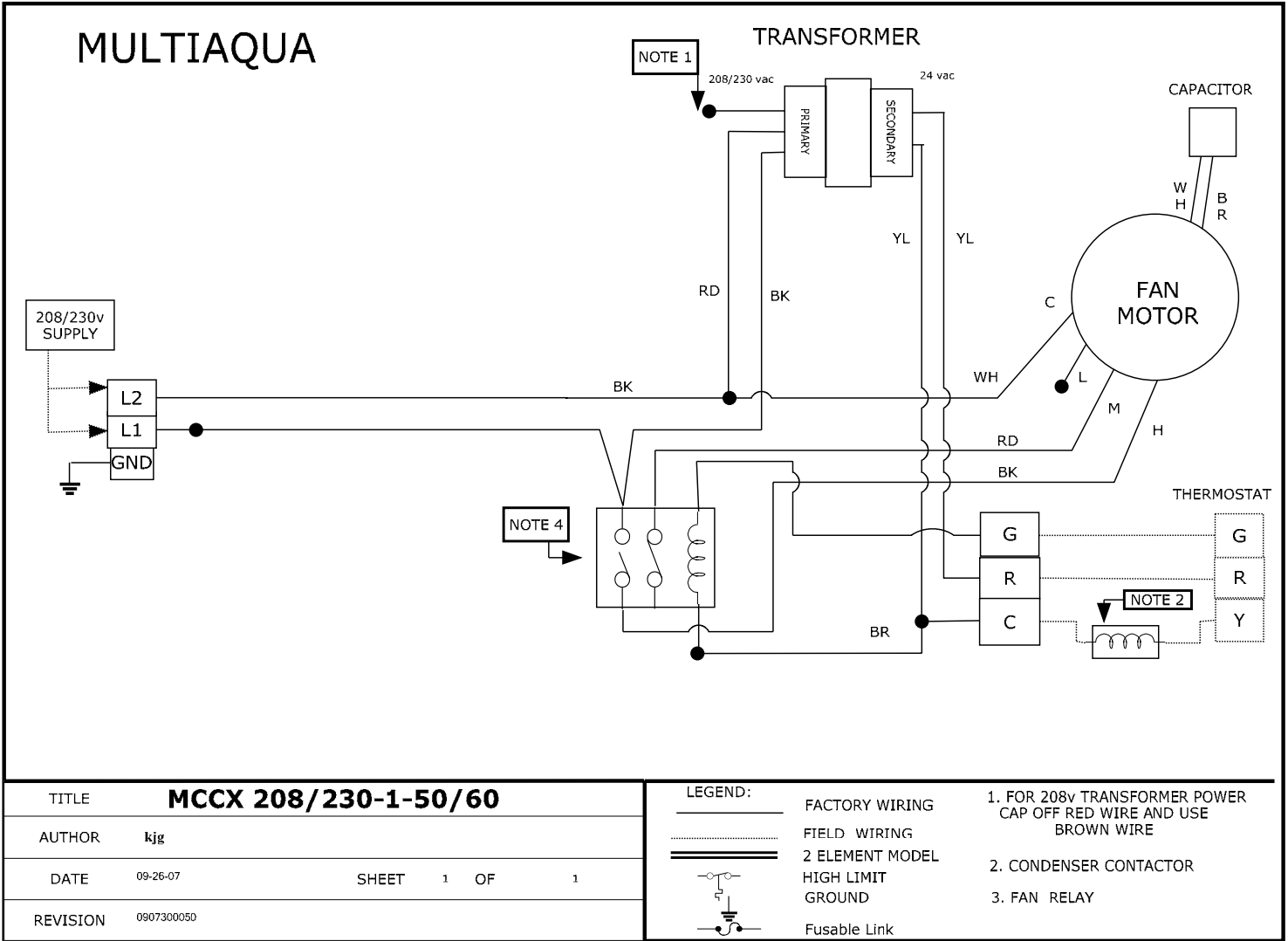

MCCX CERTIFIED DRAWING

MCCX Certified Drawing
 Drawing # 0907400075

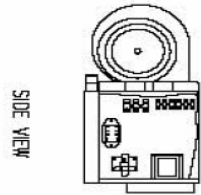

SIDE VIEW

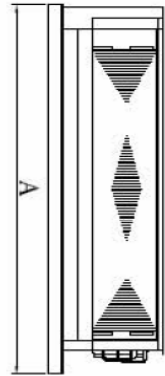

FRONT VIEW

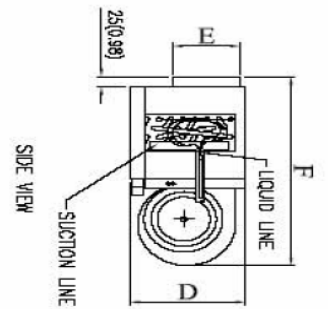

SIDE VIEW

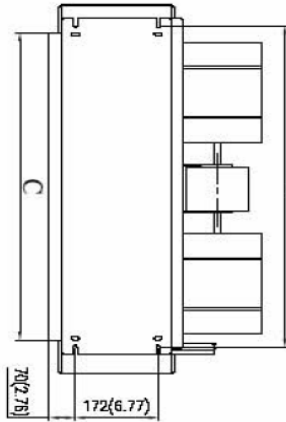

TOP VIEW

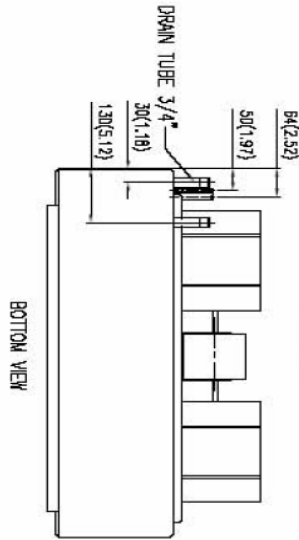

BOTTOM VIEW

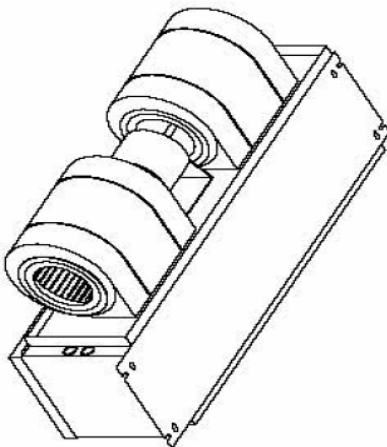

Model MCCX

| MODEL | A | B | C | D | E | F |
|-------|-------------|-------------|-------------|------------|-----------|------------|
| 04 | 958(37.72) | 843(33.19) | 801(31.54) | 247(9.72) | 139(5.47) | 455(17.91) |
| 06 | 958(37.72) | 843(33.19) | 801(31.54) | 247(9.72) | 139(5.47) | 455(17.91) |
| 08 | 958(37.72) | 843(33.19) | 801(31.54) | 247(9.72) | 139(5.47) | 455(17.91) |
| 10 | 1238(48.74) | 1123(44.21) | 1081(42.56) | 298(11.73) | 189(7.44) | 455(17.91) |
| 12 | 1238(48.74) | 1123(44.21) | 1081(42.56) | 298(11.73) | 189(7.44) | 503(19.80) |
| 16 | 1229(48.39) | 1114(43.86) | 1072(42.20) | 349(13.74) | 241(9.49) | 503(19.80) |
| 20 | 1432(56.38) | 1317(51.85) | 1275(50.20) | 349(13.74) | 241(9.49) | 503(19.80) |