



# MACH Heat Pump Air-Cooled Chiller

---

Heat Pump Air-Cooled Chillers for Global Residential  
and Light Commercial Microclimates

# MACH NOMENCLATURE BREAKDOWN

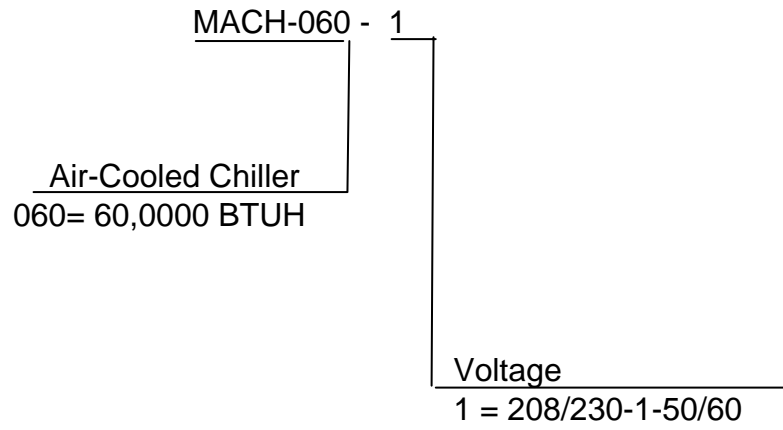

Available Model Numbers
MACH-060-1



## **HVAC Guide Specifications**

### **Heat Pump Air Cooled Liquid Chiller**

Size Range:

**5 Tons**

Multi aqua Model Number:

**MACH-060-1**

#### **Part 1 — General**

##### **1.01 SYSTEM DESCRIPTION**

Multi aqua air cooled liquid heat pump chiller are designed using a scroll compressor, low sound condenser fans and a high efficiency pump.

##### **1.02 QUALITY ASSURANCE**

- A. Unit shall be certified in accordance with U.L. Standard 95, latest revision (U.S.A)
- B. Construction shall comply with ASHRAE 15 Safety Code, NEC and ASME applicable codes (U.S.A. codes)
- C. Manufactured in a facility registered to ISO 9002, Manufacturing Quality Standard.
- D. ETL Certified.
- E. Fully load run tested at the factory.
- F. Damage resistant packaging.

##### **1.03 DELIVERY, STORAGE AND HANDLING**

- A. Packaged and readied for shipment from the factory.
- B. Unit controls shall be capable of withstanding 150F storage temperatures in the control compartment.
- C. Stored and handled per unit manufacturer's recommendations.

##### **1.04 WARRANTY**

- A. Complete unit, first year parts only warranty against manufacturer's defects.
- B. Compressor, years 2-5, parts only warranty against manufacturer's defects.

#### **Part 2 — Products**

##### **2.01 EQUIPMENT**

- A. General:
  - 1. Factory-assembled, air cooled heat pump chiller.
  - 2. Shall be assembled on heavy gauge steel mounting/lifting rails.
  - 3. Contained within the unit cabinet shall be all factory wiring, piping controls, refrigerant charge (R-407c), and special requirements prior to field start-up.
  - 4. Brass body strainer with 20 mesh screen and blow down shall be supplied in cabinet as a field installable accessory.
- B. Unit Cabinet:
  - 1. Cabinet shall be galvanized steel casing with a baked polyester powder finish.
  - 2. Cabinet shall be capable of withstanding 500-hour salt spray test in accordance with the ASTM (U.S.A) standard.
- C. Condenser Fans:
  - 1. 4-blade, condenser fans shall be direct-driven, aluminum construction, and shall be statically and dynamically balanced with inherent corrosion protection.
  - 2. Air shall be discharged horizontally.
  - 3. Motors and fans shall be protected by coated steel wire safety guards.
- D. Fan Motors:
  - 1. Condenser fan motors shall be single speed, direct drive.
  - 2. Totally enclosed.
  - 3. Permanently lubricated sleeve bearings and Class F insulation.
  - 4. Internal overload protection.
- E. Compressors:
  - 1. Fully hermetic scroll type compressor.
  - 2. Direct Drive, 3500 rpm (50/60 Hz)
  - 3. Compressor shall be suction gas cooled.
  - 4. Internal motor protected.
  - 5. Protected by high pressure and loss of charge devices.
  - 6. External vibration isolation.

- F. Pump:
  - 1. Circulating pump shall be stainless steel with high efficiency enclosed motor.
  - 2. Unit shall have chilled liquid solution piping to the exterior of the cabinet.
  - 3. Shall have a max working pressure of 60 psig.
- G. Evaporator:
  - 1. Evaporator shall have one independent refrigeration circuit and one liquid solution circuit.
  - 2. Rated for a refrigerant side working pressure of 450 psig and shall be tested for a maximum fluid-side pressure of 150 psig.
  - 2. Single pass, ANSI type 316 stainless steel, brazed plate construction.
  - 4. Insulated with closed cell, elastometric foam (ASTM 518)
- H. Condenser:
  - 1. Shall be air cooled with integral sub-cooler.
  - 2. One independent refrigeration circuit.
  - 3. Constructed of rifled copper tubing mechanically bonded to aluminum fins.
  - 3. Tubes shall be cleaned, dehydrated and sealed.
  - 4. Assembled condenser coils shall be leak tested and pressure tested at 450 psig.
- I. Refrigeration Components:
  - 1. Refrigeration circuit components shall include sight glass, reversing valve, thermal expansion device, and complete operating charge of both refrigerant (R-407c) and compressor POE oil.

### **PART 3-Controls and Safeties**

#### **3.01 Controls**

- A. Controls:

Unit control shall include the following minimum components.

  - 1. Control transformer to serve all controllers, relays and control components.
  - 2. Pump bypass timer
  - 3. Compressor recycle timer.
  - 4. Optional low pressure bypass timer for low ambient operation.
  - 5. Optional fan cycling control for low ambient operation.
  - 6. Flow switch.
  - 7. Defrost printed circuit board and thermostat.
  - 8. Leaving water temperature thermostat with thermistors installed to measure cooler leaving water flow.
  - 9. Manual heat/cool changeover switch.
- B. Unit controls shall include the following functions.
  - 1. Capacity control based on leaving chilled fluid temperature. Temperature setpoint accuracy of +/- 1.0F.
  - 2. Chilled water pump start/stop control.

#### **3.02 Safeties:**

- A. Unit shall be equipped with thermistors and all necessary components in conjunction with the control system to provide the unit with the following protectants:
  - 1. Low refrigerant pressure.
  - 2. High refrigerant pressure.
  - 3. Low liquid solution flow.
  - 4. Thermal overload.
  - 5. Short cycling.

### **PART 4 Operating Characteristics:**

#### **4.01 Temperatures**

- A. Unit shall be capable of starting and running in cooling mode at outdoor ambient temperatures from 55°F to 120°F.
- B. Optional Low Ambient Kit shall allow starting and running at outdoor temperatures to – 20°F. A field supplied and installed crankcase heater must be used when operating at these temperatures.
- C. Unit shall be capable of starting and running in heating mode at outdoor ambient temperatures from 70°F to 17°F.
- D. Unit shall be capable of starting up in cooling with a maximum 80°F and a sustained 70°F entering liquid solution temperature to the evaporator.
- E. Unit shall be capable of starting up in heating with a minimum 55°F liquid solution temperature.
- F. Minimum 10% Propylene Glycol solution is required. For outdoor temperatures below 32°, reference MAC Glycol Solution Data Table.

#### **4.02 Electrical Requirements**

- A. Primary electrical power supply shall enter the unit at a single point.
- B. Electrical power supply shall be rated to withstand 120°F operating ambient temperature.
- C. Unit shall be available in 208/230-01-50/60.
- D. Control points shall be accessed through a terminal block.

## MACH-060 Product Specifications

Physical Data										
Model Number	Coil				Chiller				Weight (lbs)	
	Height (in)	Length (in)	Copper Diameter (in)	Coil Rows	Height (in)	Length (in)	Width (in)	Refrigerant R407c	Net	Shipping
MACH060	38	48	3/8	2	49.75	39.75	16.25	92.95 oz	313	316

Electrical Data									
Model Number	Volts/ Phase/ Hertz	Compressor		Condenser Fan Motor (2 qty)		Pump Motor		Fuse or HACR Circuit Breaker Per Circuit	
		(RLA)	(LRA)	(FLA)	(RPM)	(FLA)	(RPM)	Minimum Amps	Maximum Amps
MACH060-01	208/230-1-50/60	32.1	169	1.05	1050	3.70	3450	45.93	70

	<b>MACH060</b>
Compressor	Copeland Scroll
Refrigerant	R407c
Heat Exchanger	Brazed Plate
Max. Pump Head Pressure	50 ft.
Max Flow Rate	14.4 gpm
Min Flow Rate	9.0 gpm
Supply Water Temp	44°
Return Water Temp	54°
Min. Solution Content	25 Gallons
Expansion Tank Size	2 Gallons
Pump	0.5 HP
Water Connections	1" S & 1.25" R
Internal Pressure loss	1.85 ft of head

Copper Wire Size (1% Voltage Drop)									
Supply Wire Length in Feet	200	6	4	4	4	3	3	2	2
	150	8	6	6	4	4	4	3	3
	100	10	8	8	6	6	6	4	4
	50	14	12	10	10	8	8	6	6
		15	20	25	30	35	40	45	50
Supply Circuit Ampacity									

Multi aqua chillers are designed to operate exclusively with R407c refrigerant in a self-contained, pre-charged refrigerant system. Do not access the closed refrigerant circuit for any reason other than after-sale, after installation component replacement. Routine maintenance and service is to be performed by qualified personnel only.

*These specifications are subject to change without notice.*

## MACH-060 Product Specifications

MACH-060 Capacity / Watts / EER							
O/A Temp (°F)	MACH060 COOLING			O/A Temp (°F)	MACH060 HEATING		
	Tons	KW	EER		Tons	KW	EER
82	5.1	5.3	11.55	17	3.19	4.6	8.32
95	4.9	5.9	9.97	35	3.68	4.7	9.40
100	4.8	6.1	9.44	45	4.25	4.8	10.63
105	4.7	6.4	8.81	55	4.79	4.8	11.98
110	4.7	6.5	8.68	65	5.32	4.9	13.03

Notes: Cooling is based on 44°F leaving water temperature. Heating is based on 130°F leaving water temperature

Glycol Solution Data				
Propylene Glycol %	Water Flow	Capacity	Min. Ambient Temp	GPM Adjustment= 100% Capacity
10%	x 1.020	x 0.99	26°F	x 1.01
20%	x 1.028	x 0.98	18°F	x 1.03
30%	x 1.036	x 0.98	8°F	x 1.07
40%	x 1.048	x 0.97	-7°F	x 1.11
50%	x 1.057	x 0.96	-29°F	x 1.16

Example: 30% glycol solution.

Maximum Flow Rate = 12gpm x 1.036

System capacity x .98

Use Propylene Glycol Only

### **Important**

If the outside temperature is expected to fall below freezing (32°F) in the area the Multiaqua chiller is to be installed; the installer must take the following precautions. Failure to do so will void the warranty.

**To not engage in cold ambient mitigation will result in the failure of components such as the heat exchanger, piping, circulating pump, etc... and or property damage.**

- Keep the liquid solution at a minimum of ten percent propylene glycol even in areas where there is no danger of freezing.
- The percentage amount of glycol recommended is dependent on the expected ambient temperatures and the solution makeup recommendation of the glycol manufacturer. Refer to the Glycol Solution Data table above.
- Ensure the system circulating pump is in a constant energized mode to keep a continuous circulation of liquid solution.

The Multiaqua chiller is a self-contained air-cooled condenser, coupled with an insulated brazed plate heat exchanger (evaporator). The system utilizes a scroll compressor to circulate refrigerant between the condenser and heat exchanger. The refrigerant is metered into the heat exchanger with a thermostatic expansion valve. Protecting the system are high and low pressure switches as well as a pump flow switch.

Liquid solution (water and propylene glycol; minimum 10 % is required) is circulated through the heat exchanger by an externally mounted pump. The liquid solution flows through the heat exchanger to the system supply piping and on to the air handlers.

Low ambient kits are available for operating ambient temperatures down to -20 degrees Fahrenheit. The low ambient kits consist of an ICM 325 (+) ICM (175) for single and three phase 208/230 vac chillers. For the three phase 380/460 vac chillers a pressure activated fan control is used.

*These specifications are subject to change without notice.*

## MACH060 Cooling Performance Data

<b>MACH060 CAPACITIES with 0% Glycol</b>										
LWT (°F)	ENTERING AIR TEMPERATURE (°F)									
	82		95		100		105		110	
	TONS	GPM	TONS	GPM	TONS	GPM	TONS	GPM	TONS	GPM
35	3.90	12.0	3.70	12.0	3.60	12.0	3.50	12.0	3.50	12.0
40	4.50		4.30		4.20		4.10		4.10	
42	4.80		4.60		4.50		4.30		4.40	
44	5.10		4.90		4.80		4.70		4.70	
45	5.30		5.10		5.00		4.80		4.80	
46	5.40		5.20		5.10		5.00		5.00	
48	5.80		5.60		5.40		5.30		5.30	
50	6.10		5.90		5.70		5.60		5.60	
55	7.00		6.70		6.40		6.30		6.20	
60	7.80		7.50		7.30		7.10		7.00	

<b>MACH060 CAPACITIES with 10% Glycol</b>										
LWT (°F)	ENTERING AIR TEMPERATURE (°F)									
	82		95		100		105		110	
	TONS	GPM	TONS	GPM	TONS	GPM	TONS	GPM	TONS	GPM
35	3.86	12.0	3.66	12.0	3.56	12.0	3.47	12.0	3.47	12.0
40	4.46		4.26		4.16		4.06		4.06	
42	4.75		4.55		4.46		4.26		4.36	
44	5.05		4.85		4.75		4.65		4.65	
45	5.25		5.05		4.95		4.75		4.75	
46	5.35		5.15		5.05		4.95		4.95	
48	5.74		5.54		5.35		5.25		5.25	
50	6.04		5.84		5.64		5.54		5.54	
55	6.93		6.63		6.34		6.24		6.14	
60	7.72		7.43		7.23		7.03		6.93	

<b>MACH060 CAPACITIES with 20% Glycol</b>										
LWT (°F)	ENTERING AIR TEMPERATURE (°F)									
	82		95		100		105		110	
	TONS	GPM	TONS	GPM	TONS	GPM	TONS	GPM	TONS	GPM
35	3.82	12.0	3.63	12.0	3.53	12.0	3.43	12.0	3.43	12.0
40	4.41		4.21		4.12		4.02		4.02	
42	4.70		4.51		4.41		4.21		4.31	
44	5.00		4.80		4.70		4.61		4.61	
45	5.19		5.00		4.90		4.70		4.70	
46	5.29		5.10		5.00		4.90		4.90	
48	5.68		5.49		5.29		5.19		5.19	
50	5.98		5.78		5.59		5.49		5.49	
55	6.86		6.57		6.27		6.17		6.08	
60	7.64		7.35		7.15		6.96		6.86	

*These specifications are subject to change without notice.*

## MACH060 Cooling Performance Data

<b>MACH060 CAPACITIES with 30% Glycol</b>										
LWT (°F)	ENTERING AIR TEMPERATURE (°F)									
	82		95		100		105		110	
	TONS	GPM	TONS	GPM	TONS	GPM	TONS	GPM	TONS	GPM
35	3.82	12.0	3.63	12.0	3.53	12.0	3.43	12.0	3.43	12.0
40	4.41		4.21		4.12		4.02		4.02	
42	4.70		4.51		4.41		4.21		4.31	
44	5.00		4.80		4.70		4.61		4.61	
45	5.19		5.00		4.90		4.70		4.70	
46	5.29		5.10		5.00		4.90		4.90	
48	5.68		5.49		5.29		5.19		5.19	
50	5.98		5.78		5.59		5.49		5.49	
55	6.86		6.57		6.27		6.17		6.08	
60	7.64		7.35		7.15		6.96		6.86	

<b>MACH060 CAPACITIES with 40% Glycol</b>										
LWT (°F)	ENTERING AIR TEMPERATURE (°F)									
	82		95		100		105		110	
	TONS	GPM	TONS	GPM	TONS	GPM	TONS	GPM	TONS	GPM
35	3.78	12.0	3.59	12.0	3.49	12.0	3.40	12.0	3.40	12.0
40	4.37		4.17		4.07		3.98		3.98	
42	4.66		4.46		4.37		4.17		4.27	
44	4.95		4.75		4.66		4.56		4.56	
45	5.14		4.95		4.85		4.66		4.66	
46	5.24		5.04		4.95		4.85		4.85	
48	5.63		5.43		5.24		5.14		5.14	
50	5.92		5.72		5.53		5.43		5.43	
55	6.79		6.50		6.21		6.11		6.01	
60	7.57		7.28		7.08		6.89		6.79	

<b>MACH060 CAPACITIES with 50% Glycol</b>										
LWT (°F)	ENTERING AIR TEMPERATURE (°F)									
	82		95		100		105		110	
	TONS	GPM	TONS	GPM	TONS	GPM	TONS	GPM	TONS	GPM
35	3.74	12.0	3.55	12.0	3.46	12.0	3.36	12.0	3.36	12.0
40	4.32		4.13		4.03		3.94		3.94	
42	4.61		4.42		4.32		4.13		4.22	
44	4.90		4.70		4.61		4.51		4.51	
45	5.09		4.90		4.80		4.61		4.61	
46	5.18		4.99		4.90		4.80		4.80	
48	5.57		5.38		5.18		5.09		5.09	
50	5.86		5.66		5.47		5.38		5.38	
55	6.72		6.43		6.14		6.05		5.95	
60	7.49		7.20		7.01		6.82		6.72	

*These specifications are subject to change without notice.*

## MACH060 Heating Performance Data

<b>MACH060 CAPACITIES with 0% Glycol</b>										
LWT (°F)	ENTERING AIR TEMPERATURE (°F)									
	17		35		45		55		65	
	TONS	GPM	TONS	GPM	TONS	GPM	TONS	GPM	TONS	GPM
130	3.19	12	3.68	12	4.25	12	4.79	12	5.32	12

<b>MACH060 CAPACITIES with 10% Glycol</b>										
LWT (°F)	ENTERING AIR TEMPERATURE (°F)									
	17		35		45		55		65	
	TONS	GPM	TONS	GPM	TONS	GPM	TONS	GPM	TONS	GPM
130	3.16	12	3.64	12	4.21	12	4.74	12	5.27	12

<b>MACH060 CAPACITIES with 20% Glycol</b>										
LWT (°F)	ENTERING AIR TEMPERATURE (°F)									
	17		35		45		55		65	
	TONS	GPM	TONS	GPM	TONS	GPM	TONS	GPM	TONS	GPM
130	3.13	12	3.61	12	4.17	12	4.69	12	5.21	12

<b>MACH060 CAPACITIES with 30% Glycol</b>										
LWT (°F)	ENTERING AIR TEMPERATURE (°F)									
	17		35		45		55		65	
	TONS	GPM	TONS	GPM	TONS	GPM	TONS	GPM	TONS	GPM
130	3.13	12	3.61	12	4.17	12	4.69	12	5.21	12

<b>MACH060 CAPACITIES with 40% Glycol</b>										
LWT (°F)	ENTERING AIR TEMPERATURE (°F)									
	17		35		45		55		65	
	TONS	GPM	TONS	GPM	TONS	GPM	TONS	GPM	TONS	GPM
130	3.09	12	3.57	12	4.12	12	4.65	12	5.16	12

<b>MACH060 CAPACITIES with 50% Glycol</b>										
LWT (°F)	ENTERING AIR TEMPERATURE (°F)									
	17		35		45		55		65	
	TONS	GPM	TONS	GPM	TONS	GPM	TONS	GPM	TONS	GPM
130	3.06	12	3.53	12	4.08	12	4.60	12	5.11	12

Based on compressor data.

*These specifications are subject to change without notice.*

# MACH060 Heat Pump Chiller Pump Curve

Pump Model Numbers  
 SSP-1 = 208/230-1-50/60  
 SSP-2 = 208/230/460-3-50/60  
 0.5 Horsepower

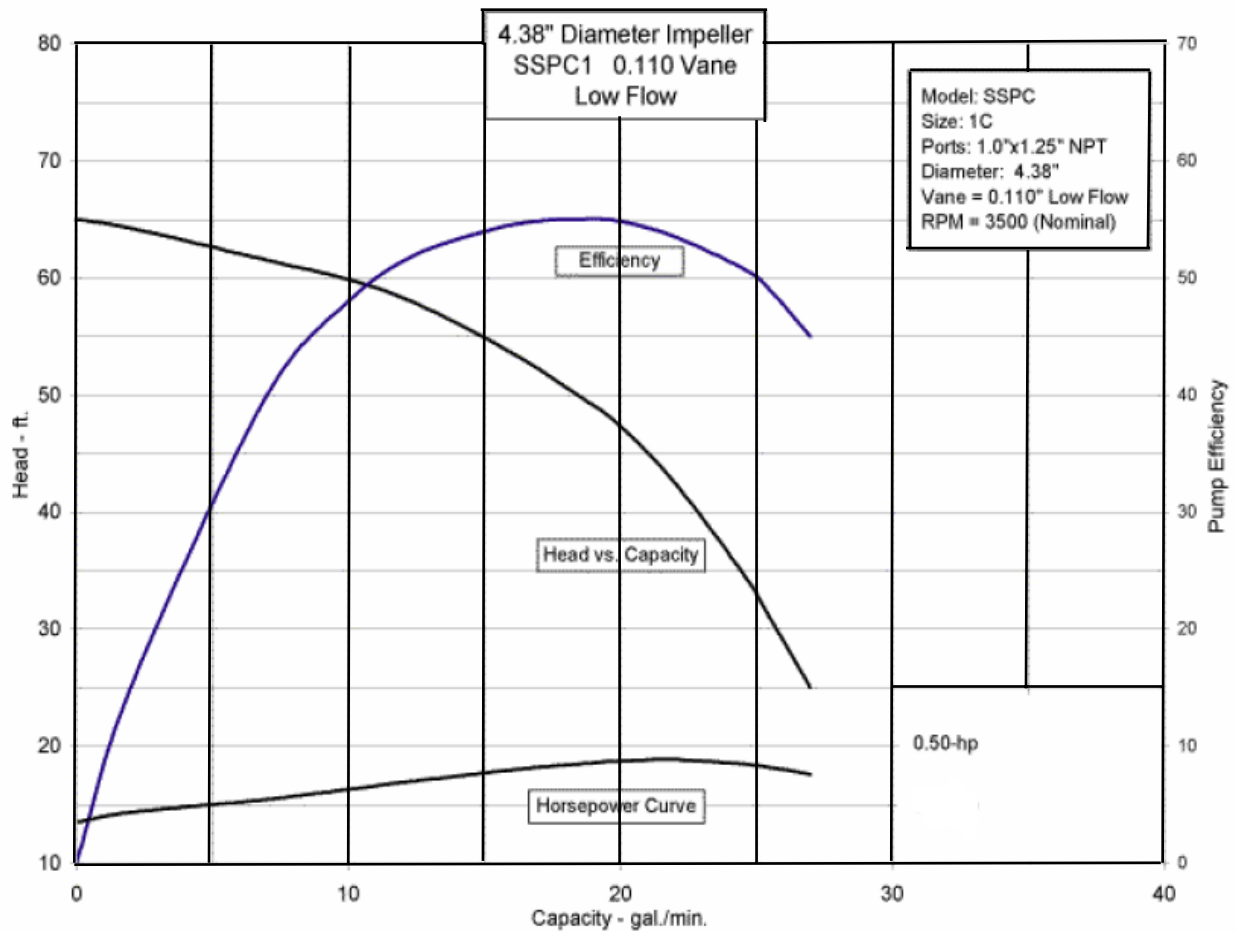

# INSTALLATION and OPERATION MANUAL



**MACH060**



# Table of Contents

	Page
<u>Introduction</u>	13
<u>System Description &amp; Sequence of Operation</u>	14
<u>Electrical &amp; Physical Data</u>	16
<u>Service Clearances</u>	17
<u>Description of Electrical Controls</u>	18
<u>Chiller Controls Sequence of Operation</u>	21
<u>Refrigeration System Operation</u>	23
<u>Description of Refrigeration Components</u>	24
<u>Piping System Components</u>	25
<u>Layout &amp; Design</u>	26
<u>Banked Chiller Configuration</u>	27
<u>Installation Notes</u>	28
<u>Propylene Glycol Content</u>	29
<u>Expansion Tank</u>	29
<u>Filling the System with Propylene Glycol</u>	30
<u>Air Elimination</u>	30
<u>Liquid Solution Balancing</u>	31
<u>Wiring Diagrams</u>	32

## **Multiaqua Heat Pump Chiller Manual**

The Multiaqua Chiller System is the only air conditioning/refrigeration system of its kind in the world today offering the degree of application flexibility described in the following manual.

The Multiaqua Chiller System is not only unique in its application flexibility; it is unique in superior quality, rated capacity and rugged durability. When installed in accordance with these instructions the system will deliver years of trouble free service.

Proper equipment sizing, piping design and installation are critical to the performance of the chiller. This manual is meant to be a “how to” introduction to piping and installing the Multiaqua Chiller System.



**RECOGNIZE THIS SYMBOL AS AN INDICATION OF IMPORTANT SAFETY OR INSTALLATION RELATED INFORMATION.**

Pressure loss information for a Composite Piping System has been used in preparing this manual. Web site information addresses are supplied throughout this manual for piping and accessory information. The plumbing industry also has pressure drop information on ferrous and copper piping systems, which will vary from the composite pipe system outlined in this manual. Composite pipe is the recommended pipe for Multiaqua Chiller System installations; however existing piping systems can be adapted to the system.

The following sections will describe each component, and how it functions within the system. Installation information is supplied where appropriate. The piping design section ( page 26) will explain the design and layout out of the piping system from a “how to” perspective. Following the examples provided will enable the installer to determine the correct pipe and accessory sizing, as well as equipment location. It is important to know before installation if the proposed system will operate correctly, and doing a formal layout of a new application or review of an existing piping system will make that determination.

Throughout this manual the term **liquid solution** is used in place of water. The chiller circulates a solution of water and Propylene Glycol.



**It is essential to operate the system with a minimum of 10% propylene glycol.**

**DO NOT OPERATE THIS SYSTEM USING WATER ALONE!**

**FOR PROPER LIQUID SOLUTIONS MIX RATIOS, REFER TO PAGE 6 OR THE GLYCOL MANUFACTURER’S RECOMMENDED MIX RATIOS.**

## System Description & Sequence of Operation



The Multiaqua MACH (Multiaqua Air Conditioning Heat Pump) is self-contained Reverse Cycle Chiller featuring dual condenser fans, direct expansion outdoor coil (air side) and a brazed plate liquid solution heat exchanger (liquid side). The outdoor coil acts as a condenser expelling heat from the refrigeration process in cooling and is an evaporator coil in the reverse cycle heat pump mode. The MACH utilizes a Sporlan™ thermostatic expansion valve (TXV) for the outdoor coil and a piston type-metering device on the liquid solution heat exchanger. In the cooling mode the outdoor coil (condenser) expansion/check valve is bypassing liquid refrigerant to the liquid solution heat exchanger (evaporator) metering device. In the heating mode (reverse cycle) the outdoor coil (evaporator) expansion/check valve is receiving condensed liquid refrigerant from the liquid solution heat exchanger (condenser) metering device. Integral safety features are included on all models; including a low water flow control, a refrigerant high and low pressure switch and a five (5) minute delay on break timer.

The system, depending on which mode has been selected (HEAT or COOL) will provide either a chilled or heated liquid solution (water and Propylene Glycol mix). The solution temperature is controlled by the liquid solution temperature control (DTC) which is factory set at 120°/44° (F). The liquid solution is circulated through the heat exchanger by an internal stainless steel pump, which is protected with Silicon Carbide-Viton Seals, to the system supply piping and to the airside fan coil/s.



**The Pump will not self-prime. A full column of liquid solution is necessary for operation. Do not attempt to operate the pump without a full charge of liquid solution or seal damage will occur.**

If the external load is a series of fan coils, each one must contain an individual zone valve to control the liquid flow. The zone valves are selected to provide the flow rate needed to achieve the proper capacity from the fan coil they control.

The temperature of the circulating liquid solution is controlled for either mode by a two (2) stage DTC (digital temperature control) with adjustable set points for precision control. A system sequence of operation, individual control description, troubleshooting information and a schematic are included in the controls section of this manual.

The liquid solution piping system suggested for new installations is a composite piping system. The composite system delivers easy on installation, low-pressure drops and will not rust or corrode. Existing and new copper or ferrous piping systems are adaptable to the Multiaqua system.

**It must be recognized that ferrous pipe may cause accelerated deterioration of the brazed plate heat exchanger and could void the heat exchanger warranty.**

*\*Also Included in this manual is a piping section that includes piping system design, installation and balancing.*



Equipment sizing for a Multiaqua solution system can utilize Load Diversity. Diversity is described as the actual amount of cooling or heating needed by various sections of a structure at a given time. Conventional central ducted air systems are designed for peak load conditions and must supply peak load capacity at all times to the conditioned space whether or not a demand exists for other zones. This introduces great system inefficiencies. A system sized to take advantage of diversity would determine the load by the time of day, building exposure, usage and adjust accordingly. To further define load diversity a structure utilizing a conventional central ducted air system would require six (6) tons of capacity at peak load. However, with the Multiaqua -MACH the specific load can be addressed and a smaller system utilized (potentially four (4) or (5) tons instead of the full capacity's 6 ton system. By taking advantage of load diversity, the system supplies the necessary amount of capacity to the spaces or zones on an as needed basis instead of producing a larger capacity 100% of the time.

To clarify this concept we will adapt the above information to a basic Multiaqua System. Utilizing diversity and a MACH-060 five (5) ton reverse cycle chiller we can supply chilled liquid solution to six (6) MHW-12 (1) ton fan coils. Three (3) of which are located in rooms facing west and three (3) in rooms facing east. Diversity dictates that the high load zones (spaces) in a building need more cooling during different times of the day. A cooling load in the morning (AM) would be greatest for portions of a structure facing east. During midday spaces with skylights or upper floors or multi-floor structures impose more loads on the system. In the afternoon (PM) the load shifts to western facing spaces of the structure. The Multiaqua system will adjust to load by supplying chiller or heated liquid solution to where and when it's needed depending on the changing load of the structure. In this simple example, it would be possible for a five (5) ton system to handle what would normally be a six-ton load on a conventionally ducted system.

Load diversity can best be determined by referring to the ACCA (Air Conditioning Contractors of America) Manual "J", refer to Appendix A-2, Multi-Zone Systems. ACCA can be located at the following Internet address: [www.acca.org](http://www.acca.org).

## ELECTRICAL AND PHYSICAL DATA

The information contained in this manual has been prepared to assist in the proper installation, operation and maintenance of the chiller. Improper installation, or installation not made in accordance with these instructions can result in unsatisfactory operation and/or dangerous conditions and can cause the related warranty not to apply.

Read this manual and any instructions packaged with separate equipment required to make up the system prior to installation. Retain this manual for future reference.



Separate and independent power supplies and disconnects must be provided. These chillers have separate and discreet power requirements within one cabinet.



All power to the chiller must be turned off prior to opening cabinet and or servicing.



Failure to properly ground chiller can result in death.



Disconnect all power wiring to chiller before maintenance or service work. Failure to do so can cause electrical shock resulting in personal injury or death.



All wiring must be done in accordance with the NEC (National Electric Code) as well as state and local codes, by qualified electricians.



Product warranty does not cover any damages or defect to the chiller caused by the attachment or use of any components, accessories or devices (other than those authorized by the manufacturer) into, onto or in conjunction with the chiller. You should be aware that the use of unauthorized components, accessories or devices may adversely affect the operation of the chiller and may also endanger life and property. The manufacturer disclaims any responsibility for such loss or injury resulting from the use of such unauthorized components, accessories or devices.



Upon receiving the chiller and components, inspect for any shipping damage. Claims for damage, either apparent or concealed should be filed immediately with the shipping company.



No liquid other than the solution of water and Propylene Glycol (mixed in accordance with table 6 page 32) shall be used in the piping system.



Corrosive environments may subject metal parts of the chiller to rust and deteriorate. The oxidation could shorten the chiller's useful life. Corrosive elements include salt spray, fog or mist in sea coastal areas, sulfur or chlorine from lawn watering systems and various chemical contaminants from industries such as paper mills and petroleum refineries.

If the unit is to be installed in an area where contaminates are likely to be a problem, special attention should be given to the equipment location and exposure.

- Avoid having lawn sprinklers spray directly on the chiller cabinet.
- In coastal areas, locate the chiller on the side of the building away from the water front.
- Elevating the chiller off of its slab or base enough to allow air circulation will help avoid holding water in contact with the cabinet base.
- Regular maintenance will reduce the build-up of contaminants and help protect the cabinet finish.
- In severe locations having the chiller coated with an "epoxy" or other coating formulated for air conditioning systems located in coastal areas may be necessary.



Consult local building codes or ordinances for special installation requirements. When selecting a site to locate the chiller, consider the following:

- A minimum clearance of 60” on the front fan discharge, 12” on the rear air inlet and a 24” clearance is required on the service side.
- The chiller can be located out or indoors. If installed indoors there must be 4500 cfm of outdoor air changes circulated through the mechanical room to sufficiently operate the chiller. No ductwork can be connected to the chiller’s condenser or condenser fans.
- If a concrete slab is used, do not connect the slab directly to any building’s foundation or structure to prevent sound transmission.
- Locate the slab on a level surface that is above grade to prevent ground water from entering the chiller cabinet.



**Regular cleaning of the cabinet air filters will be necessary. The filters clean the air which cools the circulation pump.**

### Stated Service Clearances

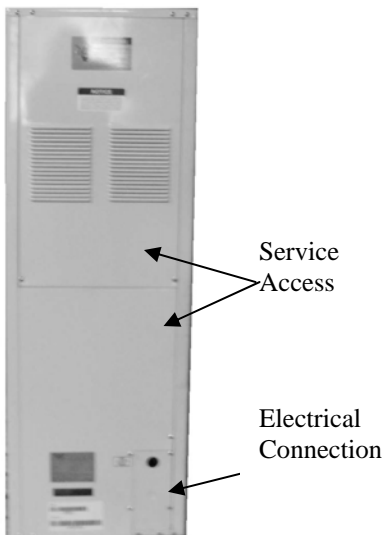
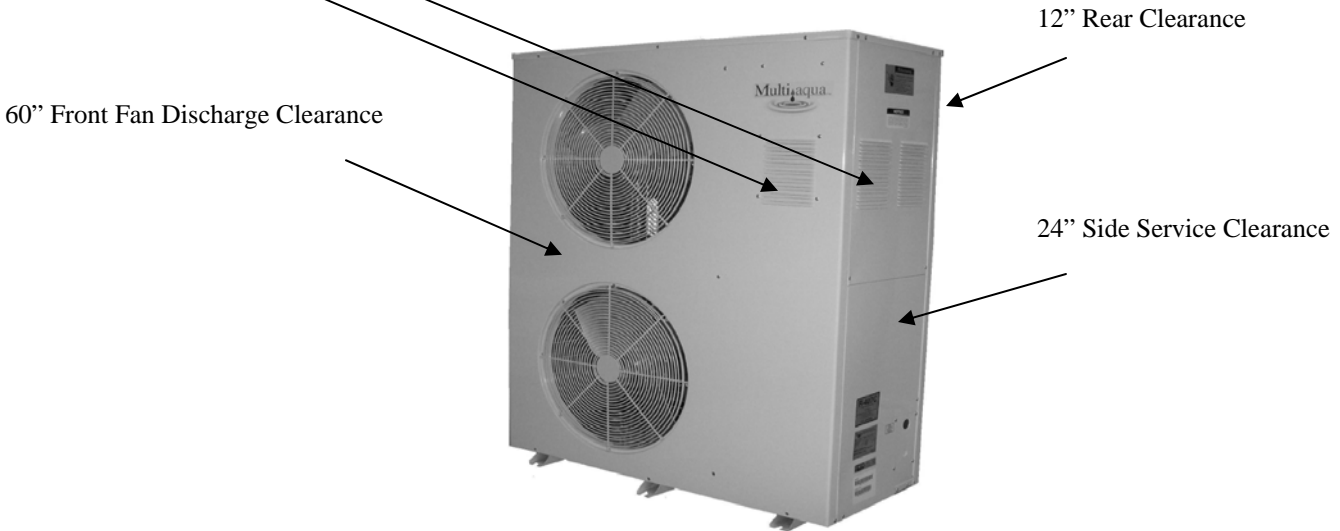

Return Liquid Solution Connection (1.25”)

Supply Liquid Solution Connection (1”)

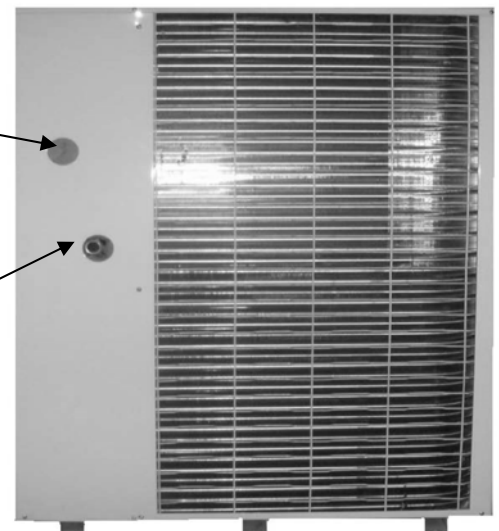

# Description of Electrical Controls

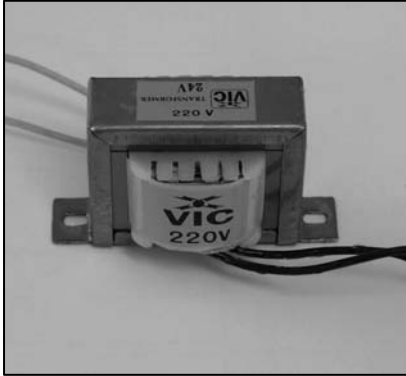

**Control Transformer:** The control transformer is rated at 24 vac, 40 va (1.6 amps @ 24vac)



**Pump Bypass Timer:** The pump bypass timer is a 24 vac, 3-wire control. When energized the timer will bypass the flow switch for 10 seconds (by creating a circuit to the pump relay), energizing the pump relay, allowing the pump to operate long enough to close the flow switch. In a normally operating system the flow switch will stay closed powering the pump relay in series with the low and high- pressure switches. Should the flow switch open, the timer can only be reset by opening and closing the chiller's line voltage disconnect.



**Refrigerant System Timer:** The refrigerant timer is a 24 vac, 5-minute delay on break, 20wire timer. The normally closed contacts of the timer energize the compressor contactor through the chilled solution control. When the chilled solution control contacts open, the timer delays by opening its contact for 5-minutes before resetting to the closed position.



**High Pressure Switch:** The high-pressure switch is an automatic reset control that senses compressor discharge line pressure. It opens at 400 PSIG and closes at 300 PSIG.

## Description of Electrical Controls (continued)



**Low Pressure Switch:** The low-pressure switch is an automatic reset control that senses compressor suction line pressure. It opens at 40 PSIG and closes at 80 PSIG.

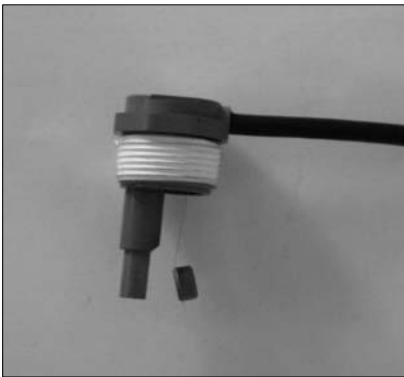

**Flow Switch:** The flow switch senses liquid solution flow. The paddle of the switch is inserted through a fitting into the pump discharge line. Liquid solution flow deflects the paddle closing the switch. The flow switch is position sensitive. The arrow ↑ on the switch must point in the direction of liquid solution flow.

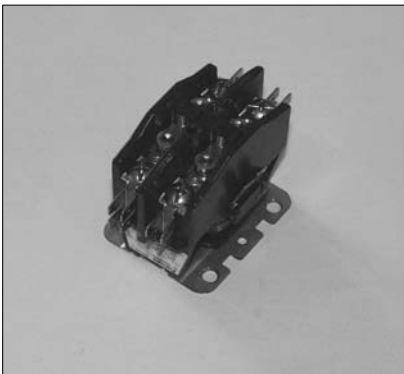

**Compressor Contactor** The compressor contactor energizes the compressor through the two or three normally open contacts. The contactor coil operates (closes the contacts) when energized by 24 vac.



**Pump Relay / Contactor:** The pump relay energizes the pump through a normally open contact. The pump relay coil operates (closes the contact) when energized by 24 vac.

## Description of Electrical Controls (continued)



**Liquid Solution Temperature Control** The liquid solution temperature control is an adjustable microprocessor based temperature control. This control receives temperature information from a thermistor located on the liquid solution supply line. A liquid crystal display continually indicates liquid solution temperature. The control is mounted inside the chiller cabinet.



**Mechanical Switch**: The mechanical switch provided in the system allows the operator to choose between one (1) of three (3) modes, "HEAT", "COOL", or system "OFF". In the system "OFF" mode all heating or cooling functions will be suspended and only liquid circulation will continue.

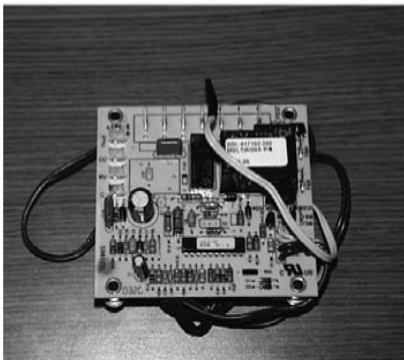

**Defrost Control Board**: The Ranco DDL demand defrost control board sees to it that the coil is defrosted when it frosts over. It's a printed circuit board with on board relays to control the outdoor fan, and reversing valve. It uses the input of coil mounted, and outdoor air sensors to determine when defrost is needed.

# Chiller Controls Sequence of Operation

*\*The paragraphs below will outline the common sequence of operation for the MACH then expand into the operation sequence for both the water heating and water chilling modes of operation. Following this information will be a section on system faults and problems solving.*



**The pump will not self-prime. A full column of liquid solution is necessary for proper operation. Do not attempt to operate the pump without a full charge of liquid solution or seal damage will occur.**

## Common Sequence of Operation

When powered up the Multiaqua Heat Pump Chiller System energizes the control system transformer (208 - 240 volts), creating 24 - volt control voltage.

First the pump bypass timer is energized and temporarily bypasses the flow switch energizing the pump relay. The pump then starts to circulate move liquid solution through the piping system (**in a properly filled and air purged system**). The circulation o liquid solution from the pump discharge keeps the flow switch closed. After a 10 second delay the pump timer contact opens, connecting the flow switch in series with the high and low-pressure switches. The pump will now run continuously unless power is interrupted or the flow switch opens.

*\*The only difference between heating and cooling modes is which coil is the evaporator and which coil is condenser. Energizing or de-energizing the reversing valve solenoid accomplishes switching coils. See reversing valve in Refrigerant Controls section.*

The mechanical (heat/cool/off) switch selects the mode of operation for the Multiaqua Heat Pump Chiller. If the switch selects off only the liquid solution pump will continue to operate. Turning the switch to heat utilizes the same sequence described below but also energized the reversing valve and the Ranco<sup>TM</sup> DDL defrost control.

If the liquid solution temperature controller (DTC) is calling for cooling the control circuit is routed through the short cycle timer, the three safety switches (the flow, low and high pressure switches), and through the Ranco<sup>TM</sup> DDL defrost control to the compressor contractor. In heating the same sequence is followed with the exception, the 24-volt signal for compressor operation is passed to and through the defrost control board, for compressor operation. once energized, the contactor starts the compressor and condenser fan motors. The liquid solution controller (DTC) will open at the user programmed set point, causing the refrigerant short cycle timer to open its contact for 5 minutes as it delays before resetting to the closed position. This will de-energize the compressor and condenser fan motors. Power fluctuations will also initiate a 5-minute time delay. The 5-minute time delay allows the refrigerant system a period for pressure equalization, protecting the compressor from short cycling.

The chiller/heat pump temperature controller utilizes a thermistor to monitor the liquid solution temperature change. The temperature is then compared to the set point and differential temperatures, programmed into the control by the user. The set point is liquid solution temperature, which will cause the control to open. A cooling example would be control set point is programmed at 44° LWT (leaving water temperature) with a 10° differential, which opens the controller at 44° LWT, and closes it at 54°. A heating example would be the control programmed at 120° LWT with a 10° differential, which opens the control at 120° and closes it at 110°. The differential temperature is the number of degrees above or below set point the temperature programmed by the user into the controller. When liquid solution temperature falls or raises to the set point the controller cycles the compressor off.

- See wiring diagram on page 9

Chillers are shipped with the digital temperature controller set at 44° LWT and a 10° differential for cooling; heating is a 120° LWT and 10° differential.

The chiller/heat pump when operating in the heating mode utilizes the outdoor coil as an evaporator. The evaporator (outdoor coil) in heating must be 20° or more below the outdoor ambient temperature. This means that on a 30° day the coil temperature will be at a 10° or below operating temperature. Operating in this temperature range causes frost to form on the outdoor coil surfaces, which cut down on the heating efficiency and capacity (BTUH). To rid the outdoor coil of this frost build up and restore heating capacity and efficiency a Ranco DDL™ Demand Defrost Control is used.

### **Demand Defrost Control**

The demand defrost control (Ranco DDL™) is a printed circuit board assembly consisting of solid-state control devices with electro-mechanical outputs. The demand defrost control monitors the outdoor ambient temperature, outdoor coil temperature, and compressor run-time to determine when a defrost cycle is required.

### **Defrost Initiation**

A defrost will be initiated when the three conditions below are satisfied:

- 1) The outdoor coil temperature is below 35°F.
- 2) The compressor has operated for at least 3 minutes with the outdoor coil temperature below 35°F.
- 3) The measured difference between the ambient temperature and the outdoor coil temperature is greater than the calculated delta T (temperature difference).

Additionally, a defrost will be initiated if six hours of accumulated compressor run-time has elapsed without defrost, and the outdoor coil temperature below 35°F.

### **Defrost Termination**

Once defrost is initiated, the defrost will continue until fourteen minutes has elapsed or the coil temperature has reached the terminate temperature. The terminate temperature is factory set at 70°F although the temperature can be changed to 50°F, 60°F, 70°, or 80° by relocating a jumper on the board (jumper and pin location center/right of board).

### **Temperature Sensors**

The coil sensor is clipped to the midsection of the outdoor coil at a point fed by the distribution tubes from the TXV (Thermostatic Expansion Valve). The air sensor is located on the defrost control board, or on a separate wire whip similar to the coil sensor, and is left hanging in the outdoor air stream.

if the ambient sensor fails the defrost control will initiate defrost every 34 minutes with the coil temperature below 35°.

If the coil sensor fails the defrost control will not initiate defrost.

### **Test Mode**

The test mode is initiated by shorting the TEST pins. In this mode of operation, the enable temperature (35°F coil) is ignored and all timers are sped up by a factor of 240. To initiate a manual defrost, short the TEST pins. Remove the short when the system switches to defrost mode. The defrost will terminate on time (14 minutes) or when the termination temperature has been achieved. Short TEST pins again to immediately terminate defrost.

## SYSTEM FAULTS:

**Flow Switch Opening:** The flow switch is normally closed during pump operation. Should liquid solution flow be interrupted for any reason the control will open, shutting down and locking out system operation. The only exception to this is when power is first applied to the unit, and the pump bypass timer bypasses the flow switch for 10 seconds. If flow is less than 3 GPM flow switch will not close.



**When the system is first filled with liquid solution and the pump started, expect the system to cycle off on the flow switch, until all of the air is removed from the piping system. The system will have to be reset by opening and then closing the disconnect switch or circuit breaker powering the system.**

**Low Pressure Switch Opening:** Should the compressor suction pressure go low enough (40 psig) to open the low-pressure switch, the compressor and outdoor fan motors will shut down. Check for a refrigerant leak, inoperative thermostatic expansion valve, low liquid solution control setting, low ambient operation, low liquid solution flow, and in heating a frosted outdoor coil, indicating potential defrost or refrigerant problems. See the electrical controls Sequence of Operation for a defrost board testing.

**High Pressure Switch Opening:** Should the compressor discharge pressure go high enough to open the high-pressure switch the compressor and outdoor fan motors will shut down. Check for a refrigerant leak, inoperative thermostatic expansion valve, low liquid solution setting, low ambient operation, low liquid solution flow, and in heating a frosted outdoor coil, indicating potential defrost or refrigerant problems. See the electrical Controls Sequence of Operation for a defrost board testing.

## **Refrigeration System Operation**

The refrigeration system is a closed loop consisting of a compressor, liquid solution side heat exchanger (evaporator in cooling & condenser in heating), airside outdoor coil (evaporator in heating and condenser on cooling), with combination Thermostatic Expansion Valve/Check Valve (TXV/Check Valve) assemblies on the systems air and liquid solution side. A reversing valve and accumulator are also in the refrigerant loop.

In cooling the hot gas is circulated from the compressor through the reversing valve to the outdoor coil (air side) where the hot gas is condensed into a liquid, then traveling through the outdoor coil mounted TXV/Check Valve, to the TXV/Check Valve on the (liquid solution) brazed plate heat exchanger, where the refrigerant pressure drops as the liquid refrigerant boils off and changes into a vapor (gas) as it picks up heat in the evaporator, then traveling to and through the reversing valve and suction line accumulator back to the compressor.

In heating the hot gas circulated from the compressor through reversing valve, traveling then to and through the TXV/Check Valve at the (liquid solution) brazed plate heat exchanger, where the hot gas is cooled by the lower temperature water circulating through the heat exchanger, condensing the refrigerant into a liquid. The now liquid refrigerant leaves the brazed plate heat exchanger traveling to the TXV/Check Valve where the refrigerant pressure drops as the liquid refrigerant boils off and changes into a vapor (gas) as it picks up heat in the evaporator, then traveling to and through the reversing valve and suction line accumulator and back to the compressor.

## Description of Refrigerant Components



**Scroll Compressor:** Scroll technology ensures reliable high efficiency. All Multiaqua units feature Scroll performance at a low sound level over a wide range of operating conditions.

**Caution must be used when near the top of the Scroll compressor. Operating temperatures can be high enough to cause serious Injury.**



**Brazed Plate Heat Exchanger:** The "Heat Exchanger" or evaporator is of a brazed copper and stainless steel design. Refrigerant and liquid solution is channeled through narrow openings between plates and flows in opposite directions. The counter flow design and fluid turbulence ensures maximum heat exchange at minimum pressure drop.



**Bi-Directional Expansion/Check Valve:** Multiaqua heat pump chillers are equipped with Thermostatic Expansion/Check Valve combination. The valves feature a liquid charged sensing bulb for constant superheat at various load conditions during the heat and cool mode of chiller operation. During the reverse cycle the internal check valve opens to allow refrigerant to flow through the valve with no pressure drop through the check valve.



**Suction Accumulator:** The suction accumulator is used to prevent excessive quantities of liquid refrigerant and oil from returning to the compressor during normal operation.



**Reversing Valve:** The four (4) way reversing valve when installed in the Multiaqua Heat Pump Chiller (MACH), reverses the direction of refrigerant flow through the heat exchanger and outdoor coil to provide heating and cooling from the system and to provide for defrosting of the outdoor coil during low ambient conditions.

# Description Of Refrigerant Components (Continued)

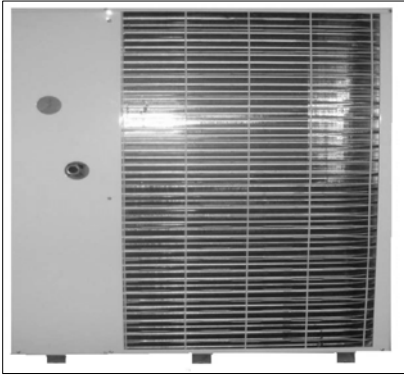

**Condenser coil:** The air-cooled condenser coil is of copper tube with aluminum fin construction. The coil is protected by a painted metal condenser grille.

## Piping System Components



**Supply Storage Tank:** The Supply Storage Tank must be used in systems with less than 25 gallons of liquid solution. The tank prevents rapid cycling of the compressor and acts as a reservoir for chilled liquid solution.

Part Number: WX202H (20 Gallon)  
WX422H (42 Gallon)

**Supply storage tank must be insulated in the field.**



**Expansion Tank and Air Scoop:** The expansion tank and air scoop assembly is used to compensate for the expansion and contraction of liquid in the system. The air scoop eliminates air entrained in the liquid solution.

Part Number: 1500/1"

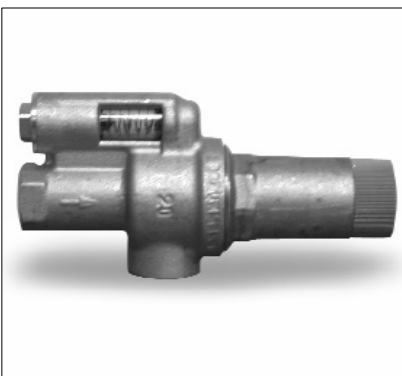

**Liquid Solution Bypass Valve:** The liquid solution bypass valve relieves system pressure from the supply loop to the return loop as the fan coil control valves are cycled off.

Part Number: D146M1032- 3/4"  
D146M1040- 1 1/4"

# Piping System Components (Continued)



**Motorized Control Valve:** The fan coil's motorized valve controls the flow of liquid solution to the system coil. Each fan coil in the system should have a motorized valve.

- Part Number: MZV524E-T 1/2" 2-Way Zone Valve
- MZV525E-T 3/4" 2-Way Zone Valve
- MZV526E-T 1" 2-Way Zone Valve
- VT3212G13A020 1/2" 3-Way Zone Valve
- VT3212G13A020 3/4" 3-Way Zone Valve

## Composite Piping Layout and Design

Understanding the function and friction loss of each part of the piping system is important to the layout and successful installation of a chilled liquid solution system.

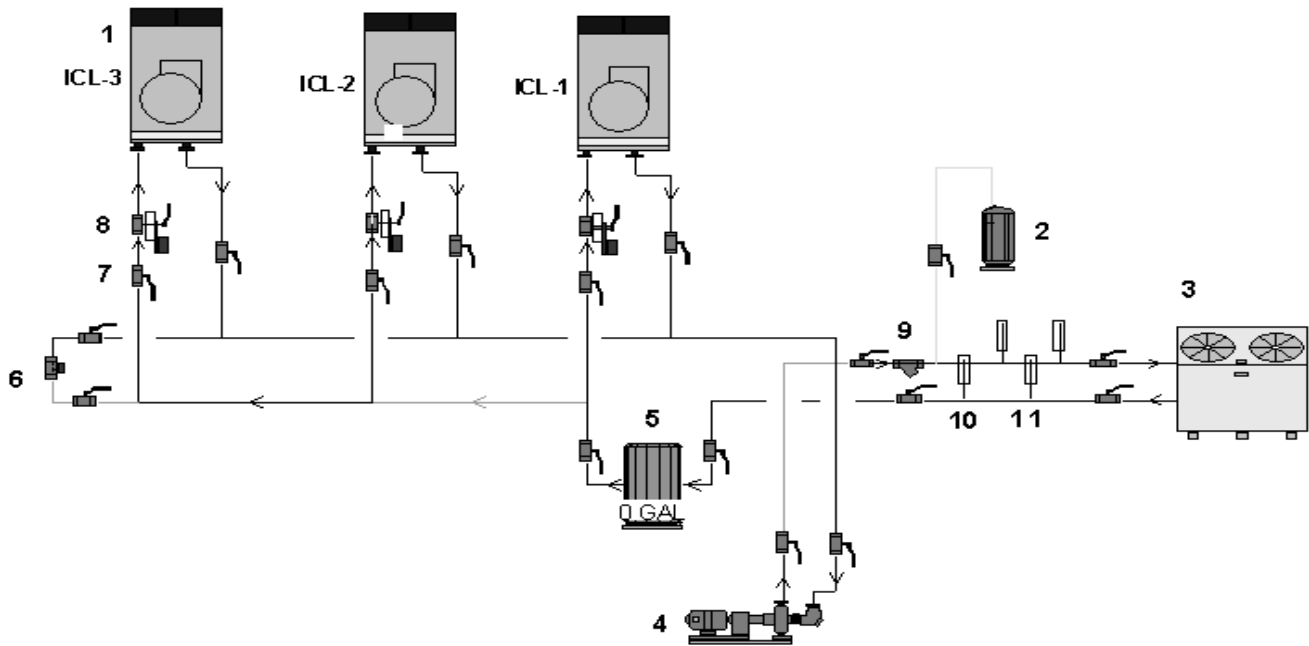

- |                   |                           |
|-------------------|---------------------------|
| 1. Fan Coil       | 7. Ball Valve             |
| 2. Expansion Tank | 8. Two Way Control Valve  |
| 3. Chiller        | 9. Wye Strainer           |
| 4. Pump           | 10. Pressure Indicator    |
| 5. Storage Tank   | 11. Temperature Indicator |
| 6. Bypass Valve   |                           |

The circulation pump is the key performer in the piping system. The pump must circulate the liquid solution through the heat exchanger and piping system to the air handlers. Pumps are designed to deliver a flow rate measured in gallons per minute (GPM). The pump must be able to overcome the resistance to flow (pressure drop) imposed by the chiller components, piping system and air handlers while maintaining the necessary flow rates in gallons per minute. Pump capacities in gallons per minute and pressure drop (feet of head) are listed in table 1.

## Banked Chiller Configuration

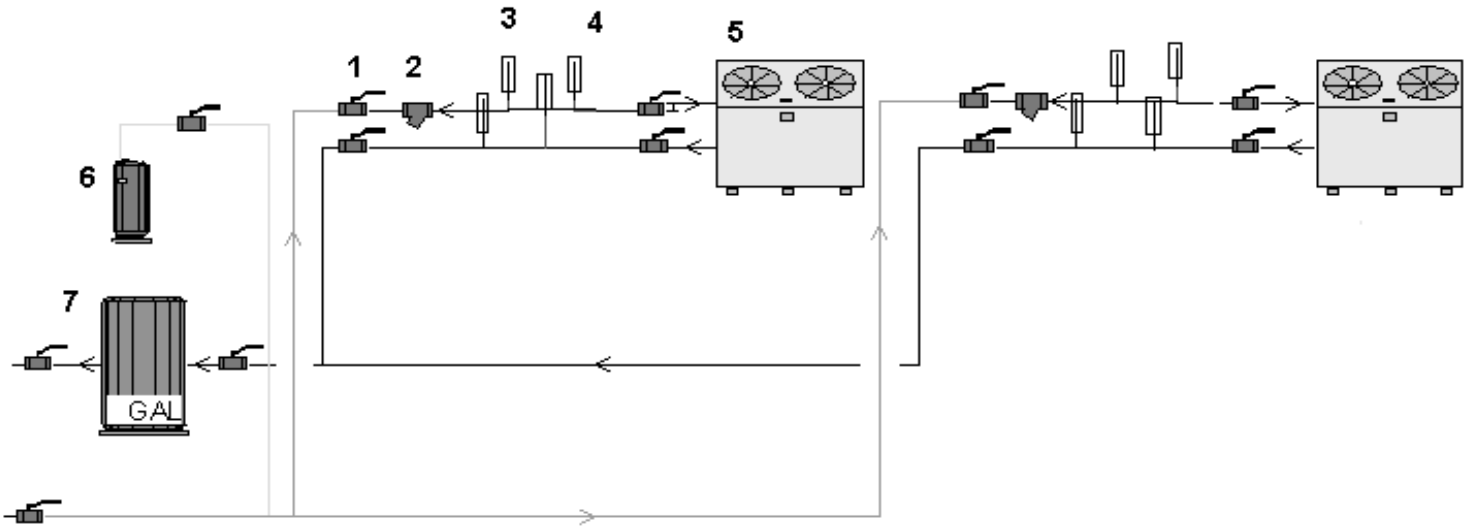

- 1. Ball Valve
- 2. Wye Strainer
- 3. Pressure Indicator
- 4. Temperature Indicator
- 5. Chiller
- 6. Expansion Tank
- 7. Storage Tank

**Notes:**

Installing Multiaqua chillers in parallel is recommended.



**An adjustable valve must be used to throttle the discharge liquid solution flow rate to appropriate levels based on capacity and glycol mix percentages.**

	MACH060
Compressor	Copeland Scroll
Refrigerant	R407c
Heat Exchanger	Brazed Plate
Max.Head Pressure	50 ft
Max Flow rate	14.4 gpm
Min Flow Rate	9.0 gpm
Supply Water Temp "C"	44° F
Return Water Temp "H"	130° F
Min Solution Content	25 gallons
Expansion Tank Size	2 Gallons
Pump	0.5 HP
Water Connections	1"Supply & 1.25" Return
Internal Pressure Loss	1.68 ft of head

Table 1

Piping resistance or pressure drop is measured in feet of head. A foot of head is the amount of pressure drop imposed in lifting liquid solution one foot. Pumps in the Multiaqua system are designed to move rated liquid solution flow in GPMs.

## Installation Notes:

 Piping such as PEX, steel, copper or PVC can be used with the Multiaqua system. Check local building codes for material conformation. Care must be taken when using PVC as the presence of propylene glycol may destroy plastics. Pressure drop data for the selected piping material is readily available and should be used. Should the Multiaqua chiller be installed using existing steel (ferrous metal) piping system, dielectric fittings must be used at the chiller and air handler. The factory supplied wye strainer will capture particles of rust and sediment inherent with steel piping and should be checked and cleaned after initial start up and opened during regular maintenance during the life of the system.

 Any piping used to conduct liquid solution must be insulated in accordance with local and national mechanical codes. Information on insulation installation and application can be obtained from Armaflex web site at [www.armacore.com](http://www.armacore.com) and Owens-Corning site at [www.owenscorning.com/mechanical/pipe/](http://www.owenscorning.com/mechanical/pipe/). For future servicing of the chiller and air handlers, it is suggested that shutoff valves be installed at the chiller and air handler(s). If ball valves are used, they can double as balancing valve (s) in the supply piping at each air handler. Chiller shut off valves should be attached at the chiller connections with unions.

 The air handlers are to be controlled with electrically operated "slow-opening" solenoid valves, circulators or motorized zone valves as manufactured by Erie controls ([www.eriecontrols.com/products/index.htm](http://www.eriecontrols.com/products/index.htm)) A remote thermostat or air handler installed digital control operates the valves.

 Bypass valves as shown in drawing 1, should be installed between the supply and the return chilled liquid solution supply pipes at a convenient location to the installation. The bypass valve operates to bypass liquid solution between the supply and return chilled liquid solution lines. In the event air handlers valves should shut down, the bypass valve is set to open up and bypass liquid solution between the supply and return lines relieving pressure and eliminating the possibility of pump cavitations. To adjust the valve, run the system with one air handler solenoid actuated. De-energize the solenoid valve, (at this point no liquid solution will be flowing through the air handlers.) and adjust the bypass valve to relieve pressure between the supply and return piping.

 Bleed ports will be factory installed on all Multiaqua air handlers. Bleed ports are opened to eliminate air trapped in the air handlers after filling the system with liquid solution and Propylene Glycol, and before operating the refrigerant compressor in the chiller.

 The minimum liquid solution content in the chiller system, (piping, chiller, and air handlers), is 25 U.S. gallons. Estimate the system liquid solution content. Should the system have less than 50 gallons of liquid solution content, a chilled liquid solution storage tank must be installed. The tank stores enough chilled liquid solution to prevent frequent chiller compressor cycles at light load and prevents chilled liquid temperature swings at higher load conditions when the chiller compressor is waiting to cycle on the time delay control.

 Propylene Glycol must be added to the water used in the system. Propylene helps prevent freeze-ups due to low ambient temperature conditions and low chilled liquid solution temperatures. In comparison to water, Propylene Glycol slightly lessens the temperature exchange in the chiller heat exchanger. However, that is offset by the increased flow of liquid solution through the piping system enabled by the Propylene Glycol. To determine the Propylene Glycol content for various ambient temperatures refer to table 6 page 29.

 In no instance should a Multiaqua chiller be installed with less than 10% Propylene Glycol content in the piping system. Using less than the recommended Propylene Glycol percentage content voids equipment warranty.

## Installation Notes: (Continued)



Ethylene Glycol is environmentally hazardous and not recommended. Inhibited Propylene Glycol ( typical automotive coolant) is not to be used in a Multiaqua Chiller under any circumstances. Dow Chemical's "Ambitrol" family of Glycol-based coolants of food grade Propylene Glycol is suggested. Information on Ambitrol is available from Dow at [www.dow.com](http://www.dow.com), search word "Ambitrol".

% of Propylene Glycol to Water Content			
Minimum Ambient Temp. F.	Glycol %	Capacity	GPM Adjustment = 100 Capacity
26	10%	x .99	x 1.01
18	20%	x .98	x 1.03
8	30%	x .98	x 1.07
-7	40%	x .97	x 1.11
-29	50%	x .96	x 1.16

### Expansion Tank

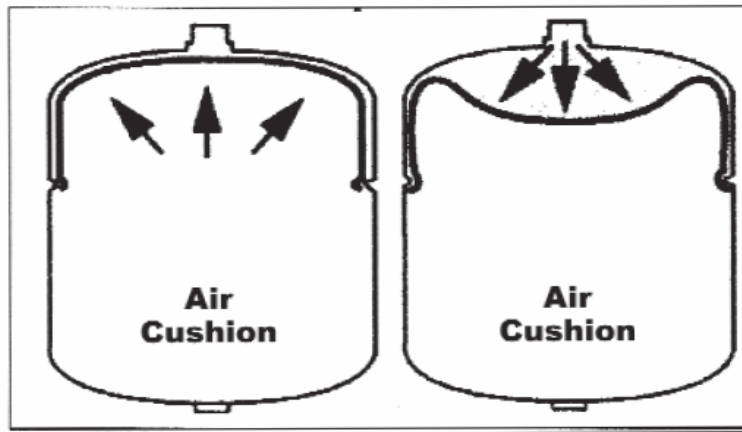

Liquid solution expansion and contraction within the closed system must be compensated for with an expansion tank. The expansion tank used with the Multiaqua system, is a steel tank with a rubber bladder attached to it internally. There is air pressure on one side of the rubber bladder that keeps the bladder pushed against the sides of the tank before the system is filled with liquid solution (illustration above). As the liquid solution heats up the bladder, will be pushed further away from the tank walls, allowing for expansion and contracting as the liquid solution temperature changes. By flexing, the bladder controls the system pressure adjusting to temperature variations of the chilled liquid solution system.





It is critical that the expansion tank's air bladder pressure be less than the system solution pressure. Air pressure can be measured with an automotive tire gauge at the bicycle valve port on the expansion tank. Bleeding air out of the bladder or increasing the pressure with a bicycle pump will adjust pressure.



System must use a liquid solution storage tank if system volume is less than 25 U.S. gallons.

# Filling System with Liquid Solution and Coolant (Propylene Glycol)

 Concentrations of Propylene Glycol in excess of 50% will destroy o-rings in fittings and pump. Water should be added to the system first or a liquid solution diluted Propylene Glycol mix.

 Before filling system with Propylene Glycol and water, pressure test the piping system with compressed air. Testing should be done at a minimum of 50 psi but no greater than 50 psi over the system's normal operating pressure. The system should hold air pressure for a minimum of one hour with no leakage.

System that contains 50 or more U.S. gallons should have a tee fitting with a stopcock installed in the return line close to the chiller. The stopcock can be opened and attached to a hose with a female X female hose fitting. In the open end of the hose section (1 -1.5 feet long) insert a funnel and pour into the system the diluted Propylene Glycol/liquid solution mixture or add water first and then the quantity of Propylene Glycol needed for minimum ambient protection (refer to Table 6). After adding the Propylene Glycol /water mixture or liquid solution and then coolant proceed to add enough water to the system to achieve a 15 psi gauge pressure. To measure system pressure shut off the stopcock, remove hose and attach a water pressure gauge. Open the stopcock to read system pressure.

Systems that use the Chilled Liquid Solution Storage Tank should be filled at the tee/stopcock fitting in the outlet fitting of the storage tank. Fill the tanks with 10 gallons of water and with a funnel pour the calculated (refer to Table 6) amount of Propylene Glycol into the tank. The amount of Propylene Glycol added should be calculated to achieve minimum ambient protection. After adding Propylene Glycol, fill the system with enough liquid solution to bring system pressure to approximately 15 psi gauge pressure. To measure system pressure shut off the stopcock and attach a water pressure gauge. Open the stopcock to read system pressure.

## **Air Elimination**

Since we have the system filled we must eliminate the air left in the system. Briefly open each bleed valve at the air handlers and allow trapped air to escape. This will eliminate much of the air left in the system. Next we will start the pump and continue bleeding air from the system. Be sure the chiller has line voltage available to it and set the chilled liquid solution control up to 100°F, which will ensure that only the pump runs at this point. The pump should now start and remain running. Should the pump stop at any time during this process it is an indication that the flow switch had air move across it allowing the circuit to be interrupted. Continue to bleed some air out of the system at the highest locations before resetting the pump bypass timer to get the pump running again. Open and close the power supply switch to the chiller to restart the pump. Continue bleeding air with the pump operating. You may have to start and re-start the pump a few times to complete air removal.

 All piping systems should have a minimum of 10% Propylene Glycol in the system even in climates with no freezing ambient temperatures.

 Using less than the recommended Propylene Glycol percentage content voids equipment warranty.

 Liquid solution control valves (solenoid or motorized valves) should be selected for low pressure drop. If a selected valve contributes to pushing your total head calculation to more than 50 feet of head, a larger valve may be needed to bring your total head below the maximum of 50 feet.

## **Liquid Solution Balancing:**

Liquid solution balancing will require an accurate digital thermometer to measure return line liquid solution temperature at each air handler. Set the chilled liquid solution temperature control in the chiller at a normal operational temperature (44°F) and measure pump discharge temperature with the digital thermometer to check system solution temperature. After the chilled liquid solution temperature has lowered to the set point begin the balancing process. The system must be free of air and each air handler set at a temperature low enough to continue cooling operation (and liquid solution flow) during the balancing process. Begin by measuring the return line chilled liquid solution temperature of each air handler. Begin incrementally closing supply line balance valve at the air handlers with the lowest return line chilled liquid solution temperature. Continue this process until each air handler has close to the same return line chilled liquid solution temperat

# MACH060-01 Wiring Diagram

208/230-1-50/60

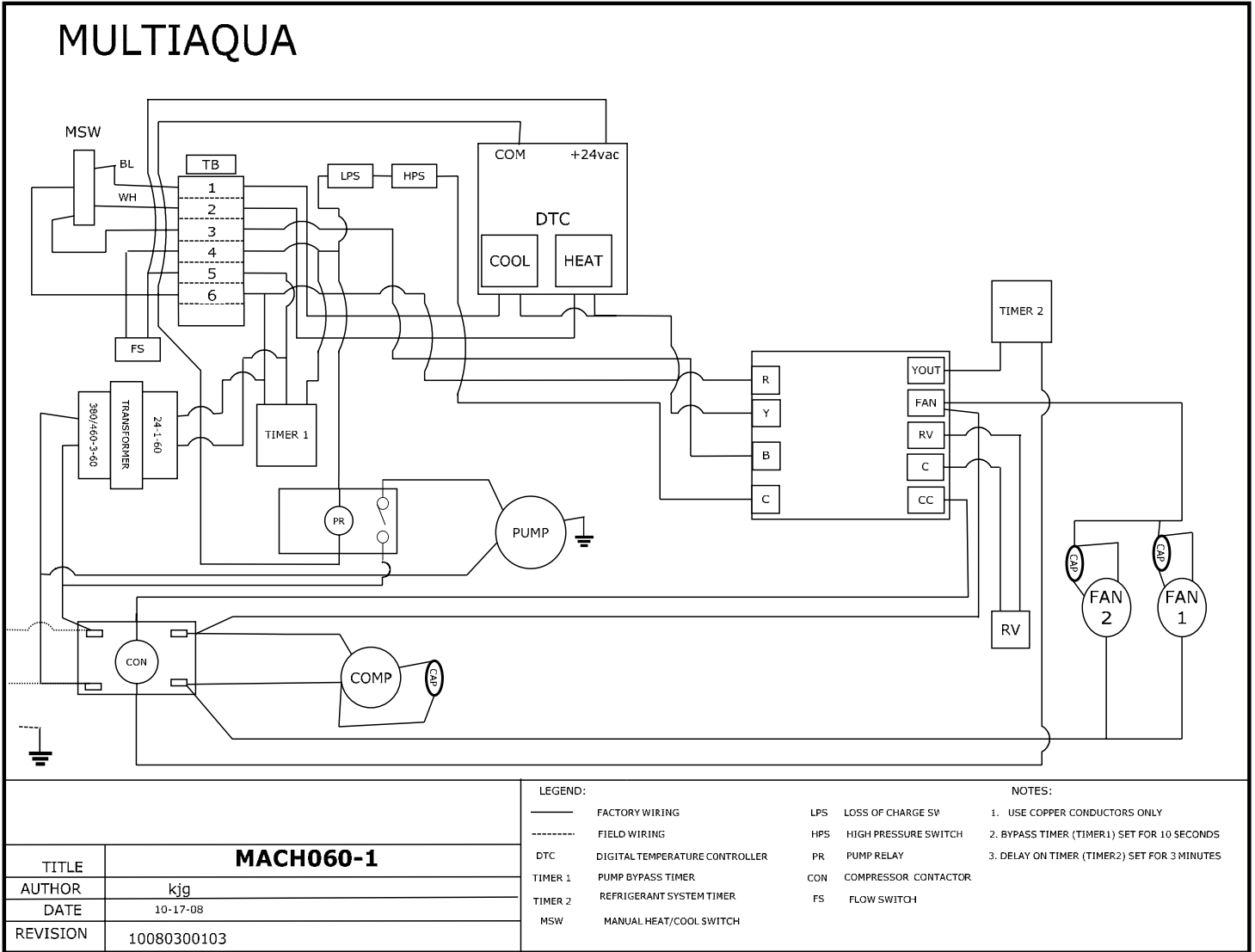

# MACH060-01 with Low Ambient Kit Wiring Diagram

208/230-1-50/60

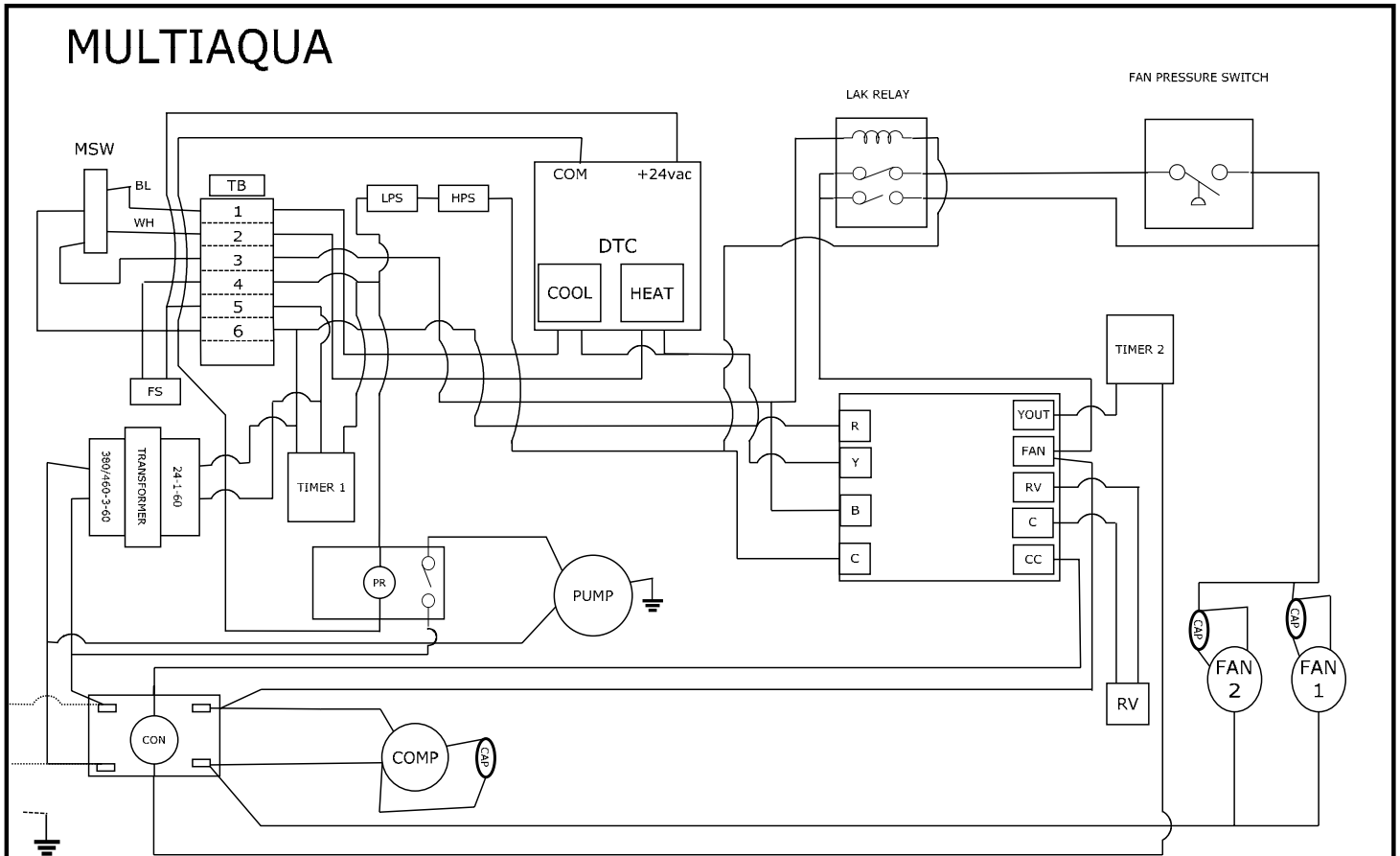

TITLE		LEGEND:		NOTES:	
<b>MACH060-1 WITH LAK</b>		————	FACTORY WIRING	LPS	LOSS OF CHARGE SWITCH
AUTHOR	kjg	-----	FIELD WIRING	HPS	HIGH PRESSURE SWITCH
DATE	09-09-08	DTC	DIGITAL TEMPERATURE CONTROLLER	PR	PUMP RELAY
REVISION	0908300101	TIMER 1	PUMP BYPASS TIMER	CON	COMPRESSOR CONTACTOR
		TIMER 2	REFRIGERANT SYSTEM TIMER	FS	FLOW SWITCH
		MSW	MANUAL HEAT/COOL SWITCH		