



CWA4 Chilled & Hot Water Fan Coil

4-Pipe Heat & Cool Fan Coil 24,000 - 60,000 BTUH

CWA4 NOMENCLATURE BREAKDOWN

4-Pipe Heat & Cool Multiposition Fan Coil

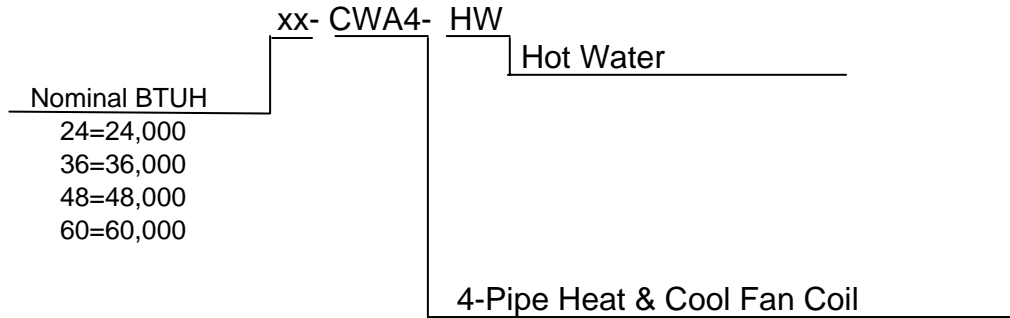

Note:

The CWA4 is only available in 120-1-60 vac

Available Model Numbers	
	24CWA2-HW
	36CWA4-HW
	48CWA4-HW
	60CWA4-HW

HVAC Guide Specifications

Chilled & Hot Water Multi-Position Fan Coil
4-Pipe

Nominal Size:

24,000 – 60,000 BTUH

MultiAqua Model Number:

24CWA4

36CWA4

48CWA4

60CWA4

Part 1-General

1.01 System Description

MultiAqua Chilled Water Fan Coils are manufactured with heavy gauge galvanized steel to resist corrosion.

1.02 Quality Assurance

- A. Certified in accordance with U.L. Standard 95, latest version (U.S.A.)
- B. Manufactured in a facility registered to ISO 9002, Manufacturing Quality Standard.
- C. Fully load tested at the factory.
- D. Damage resistant packaging.

1.03 Delivery, Storage and Handling

- A. Packaged and readied for shipment from the factory.
- B. Controls shall be capable of withstanding 150°F storage temperatures in the control compartment.
- C. Stored and handled per manufacturer's recommendations.

Part 2-Product

2.01 Equipment

- A. General:
 1. Unit shall be a factory assembled and tested multi-position chilled & hot water fan coil.
 2. Shall be assembled with high quality.
 3. Contained with the unit shall be all factory wiring, piping, associated controls and special accessories required prior to start up.
- B. Unit Cabinet:
 1. Composed of heavy gauge galvanized steel casing with baked polyester powder.
 2. Shall be internally insulated to insure quiet operation.
 3. Cabinet shall be capable of being installed in a vertical or horizontal position.
- C. Fan Motors:
 1. Shall be available in 120-1-60 vac.
 1. Fan motors shall be three speed, direct drive, and PSC type.
 2. Internal overload protected.
- D. Blower Wheels:
 1. Blower wheels are forward curved and dynamically balanced.
- E. Water Coil:
 1. Manufactured with a chilled water coil containing 3/8" copper tubing mechanically bonded to aluminum fins.
 2. Manufactured with a hot water coil containing 3/8" copper tubing mechanically bonded to aluminum fins.
 3. Coils shall be factory tested to 350 psig.
 4. Coil shall contain manual air bleed port.
- F. Drain Pan:
 1. Drain pan shall be molded with high impact polymers.
 2. Pan shall contain a primary and secondary drain connection.
 3. Pan shall be capable of draining in the vertical and horizontal positions without changing the pan configuration.

G. Filters:

1. Unit shall contain a filter door for easy access to the filter.
2. A filter track shall be provided.
3. Unit shall come supplied with a 1" throwaway filter.

H. Hot Water Pump

1. Unit shall contain an internal hot water circulating pump.

Part 3-Controls and Safeties

3.01 Controls

- A. Fan coils shall be completely factory wired and tested.
- B. Unit shall include a terminal block that is capable of incorporating a 24 vac thermostat.

3.02 Safeties:

- A. Fan coil shall contain a non reusable fuse on the secondary voltage side of the transformer.

Part 4-Operating Characteristics:

4.01 Electrical Requirements

- A. Electrical shall include a terminal block.
- B. Electrical power supply shall be rated to withstand 120°F operating ambient temperatures.

CWA4 Product Specifications

Physical Data												
Model Number	Height (in)	Length (in)	Depth (in)	Weight (lbs)	Cooling Rows FPI	Heating Rows FPI	Copper Diameter (in)	Chilled Water Inlet (in)	Chilled Water Outlet (in)	Hot Water Inlet (in)	Hot Water Outlet (in)	Drain (in)
24CWA4	39.75	17.5	21	140	4-14	3-12	3/8	1/2	1/2	1/2	1/2	3/4
36CWA4	39.75	17.5	21	175	4-14	3-12	3/8	3/4	3/4	1/2	1/2	3/4
48CWA4	49.75	21.5	25	189	4-14	3-12	3/8	3/4	3/4	1/2	1/2	3/4
60CWA4	49.75	21.5	25	199	4-14	3-12	3/8	3/4	3/4	1/2	1/2	3/4

Electrical Data								
Model Number	Nominal CFM	Volts/Phase/Hertz	Fan Motor HP	Full Load Ampacity	Pump Motor HP	Hot Water Pump Full Load Ampacity	Fuse or HACR Circuit Breaker Per Circuit	
							Minimum Amps	Maximum Amps
24CWA4	800	120-1-60	1/4	3.2	1/40	0.52	3.77	9
36CWA4	1200		1/3	6.2	1/40	0.52	8.0	15
48CWA4	1600		3/4	8.9	1/40	0.52	12	20
60CWA4	2000		3/4	8.9	1/25	0.75	12	20

These specifications are subject to change without notice.

CWA4 Chilled Water Performance Data

24CWA4-HW COOLING CAPACITIES					
NOMINAL CFM	EWT (°F)	GPM	WPD	ENTERING AIR TEMPERATURE	
				80° D.B. / 67° W.B.	
600	42	3.0	2.2	TC	16.5
				SC	12.4
				APD	0.14
		4.5	4.7	TC	18.4
				SC	13.8
				APD	0.14
		6.0	8.2	TC	19.7
				SC	14.7
				APD	0.14

24CWA4-HW COOLING CAPACITIES					
NOMINAL CFM	EWT (°F)	GPM	WPD	ENTERING AIR TEMPERATURE	
				80° D.B. / 67° W.B.	
800	42	3.5	2.9	TC	20.9
				SC	15.7
				APD	0.21
		5.0	5.8	TC	22.9
				SC	17.2
				APD	0.21
		6.5	9.6	TC	24.4
				SC	18.3
				APD	0.21

24CWA4-HW COOLING CAPACITIES					
NOMINAL CFM	EWT (°F)	GPM	WPD	ENTERING AIR TEMPERATURE	
				80° D.B. / 67° W.B.	
600	45	3.0	2.2	TC	15.7
				SC	12.7
				APD	0.14
		4.5	4.7	TC	17.3
				SC	13.8
				APD	0.14
		6.0	8.2	TC	18.3
				SC	14.6
				APD	0.14

24CWA4-HW COOLING CAPACITIES					
NOMINAL CFM	EWT (°F)	GPM	WPD	ENTERING AIR TEMPERATURE	
				80° D.B. / 67° W.B.	
800	45	3.5	2.9	TC	19.8
				SC	15.8
				APD	0.21
		5.0	5.8	TC	21.6
				SC	17.3
				APD	0.21
		6.5	9.6	TC	22.9
				SC	18.3
				APD	0.21

These specifications are subject to change without notice.

CWA4 Chilled Water Performance Data

36CWA4-HW COOLING CAPACITIES					
NOMINAL CFM	EWT (°F)	GPM	WPD	ENTERING AIR TEMPERATURE	
				80° D.B. / 67° W.B.	
1000	42	4.0	2.1	TC	26.0
				SC	19.5
				APD	0.2
		6.0	4.6	TC	29.0
				SC	21.8
				APD	0.2
		8.0	8.1	TC	31.0
				SC	23.2
				APD	0.2

36CWA4-HW COOLING CAPACITIES					
NOMINAL CFM	EWT (°F)	GPM	WPD	ENTERING AIR TEMPERATURE	
				80° D.B. / 67° W.B.	
1200	42	5.0	3.3	TC	31.2
				SC	23.3
				APD	0.3
		6.5	5.4	TC	33.3
				SC	25.0
				APD	0.3
		8.0	8.1	TC	35.0
				SC	26.3
				APD	0.3

36CWA4-HW COOLING CAPACITIES					
NOMINAL CFM	EWT (°F)	GPM	WPD	ENTERING AIR TEMPERATURE	
				80° D.B. / 67° W.B.	
1000	45	4.0	2.1	TC	24.8
				SC	19.8
				APD	0.23
		6.0	4.6	TC	27.3
				SC	21.8
				APD	0.23
		8.0	8.1	TC	29.0
				SC	23.2
				APD	0.23

36CWA4-HW COOLING CAPACITIES					
NOMINAL CFM	EWT (°F)	GPM	WPD	ENTERING AIR TEMPERATURE	
				80° D.B. / 67° W.B.	
1200	45	5.0	3.3	TC	29.6
				SC	23.7
				APD	0.28
		6.5	5.4	TC	31.5
				SC	25.2
				APD	0.28
		8.0	8.1	TC	31.9
				SC	25.5
				APD	0.28

These specifications are subject to change without notice.

CWA4 Chilled Water Performance Data

48CWA4-HW COOLING CAPACITIES					
NOMINAL CFM	EWT (°F)	GPM	WPD	ENTERING AIR TEMPERATURE	
				80° D.B. / 67° W.B.	
1400	42	4.5	1.2	TC	33.4
				SC	25.0
				APD	0.24
		6.0	2.2	TC	36.3
				SC	27.2
				APD	0.24
		7.5	3.3	TC	38.5
				SC	28.9
				APD	0.24

48CWA4-HW COOLING CAPACITIES					
NOMINAL CFM	EWT (°F)	GPM	WPD	ENTERING AIR TEMPERATURE	
				80° D.B. / 67° W.B.	
1600	42	6.0	2.2	TC	39.5
				SC	29.6
				APD	0.25
		8.0	3.8	TC	42.7
				SC	32.0
				APD	0.25
		10.0	5.8	TC	45.1
				SC	33.8
				APD	0.25

48CWA4-HW COOLING CAPACITIES					
NOMINAL CFM	EWT (°F)	GPM	WPD	ENTERING AIR TEMPERATURE	
				80° D.B. / 67° W.B.	
1400	45	4.5	1.2	TC	32.0
				SC	25.6
				APD	0.24
		6.0	2.2	TC	34.5
				SC	27.6
				APD	0.24
		7.5	3.3	TC	36.4
				SC	29.1
				APD	0.24

48CWA4-HW COOLING CAPACITIES					
NOMINAL CFM	EWT (°F)	GPM	WPD	ENTERING AIR TEMPERATURE	
				80° D.B. / 67° W.B.	
1600	45	6.0	2.2	TC	37.7
				SC	30.2
				APD	0.25
		8.0	3.8	TC	40.5
				SC	32.4
				APD	0.25
		10.0	5.8	TC	42.6
				SC	34.1
				APD	0.25

These specifications are subject to change without notice.

CWA4 Chilled Water Performance Data

60CWA4-HW COOLING CAPACITIES					
NOMINAL CFM	EWT (°F)	GPM	WPD	ENTERING AIR TEMPERATURE	
				80° D.B. / 67° W.B.	
1600	42	6.5	2.8	TC	42.5
				SC	31.9
				APD	0.19
		8.5	4.6	TC	45.6
				SC	34.2
				APD	0.19
		10.5	6.9	TC	48.1
				SC	36.1
				APD	0.19

60CWA4-HW COOLING CAPACITIES					
NOMINAL CFM	EWT (°F)	GPM	WPD	ENTERING AIR TEMPERATURE	
				80° D.B. / 67° W.B.	
2000	42	7.0	3.2	TC	50.0
				SC	37.5
				APD	0.27
		10.0	6.3	TC	55.1
				SC	41.3
				APD	0.27
		13.0	10.5	TC	58.7
				SC	44.0
				APD	0.27

60CWA4-HW COOLING CAPACITIES					
NOMINAL CFM	EWT (°F)	GPM	WPD	ENTERING AIR TEMPERATURE	
				80° D.B. / 67° W.B.	
1600	45	6.5	2.8	TC	40.4
				SC	32.3
				APD	0.19
		8.5	4.6	TC	43.1
				SC	34.5
				APD	0.19
		10.5	6.9	TC	45.2
				SC	36.2
				APD	0.19

60CWA4-HW COOLING CAPACITIES					
NOMINAL CFM	EWT (°F)	GPM	WPD	ENTERING AIR TEMPERATURE	
				80° D.B. / 67° W.B.	
2000	45	7.0	3.2	TC	47.7
				SC	36.2
				APD	0.27
		10.0	6.3	TC	52.1
				SC	41.7
				APD	0.27
		13.0	10.5	TC	55.2
				SC	44.2
				APD	0.27

These specifications are subject to change without notice.

CWA4 Hot Water Performance Data

24CWA4-HW HEATING CAPACITIES									
ENTERING AIR (°F)	CFM	GPM	WPD						
				130°	140°	150°	160°	170°	180°
65	800	4.0	1.9	23000	26000	30300	33900	37600	41200

36CWA4-HW HEATING CAPACITIES									
ENTERING AIR (°F)	CFM	GPM	WPD						
				130°	140°	150°	160°	170°	180°
65	1200	4.0	1.4	45000	50000	60000	67000	74800	82000

48CWA4-HW HEATING CAPACITIES									
ENTERING AIR (°F)	CFM	GPM	WPD						
				130°	140°	150°	160°	170°	180°
65	1600	4.0	0.8	59000	67000	78000	88000	97000	107000

60CWA4-HW HEATING CAPACITIES									
ENTERING AIR (°F)	CFM	GPM	WPD						
				130°	140°	150°	160°	170°	180°
65	2000	7.0	2.5	69000	80000	91000	102500	113500	125000

These specifications are subject to change without notice.

CWA4 CFM and Glycol Adjustments

Model Number	Moter Speed	CFM vs. ESP				
		0.1	0.2	0.3	0.4	0.5
24CWA4-HW	High	850	800	760	720	680
	Medium	825	775	715	690	670
	Low	780	715	655	630	-
36CWA4-HW	High	1360	1310	1270	1230	1190
	Medium	1340	1250	1170	1090	1060
	Low	1280	1170	1040	970	-
48CWA4-HW	High	1860	1740	1640	1530	1480
	Medium	1780	1620	1510	1390	1280
	Low	1680	1500	1320	1250	-
60CWA4-HW	High	1950	1900	1845	1770	1720
	Medium	1820	1750	1620	1470	1440
	Low	1750	1640	1390	1270	-

Example:

24CWA4 @ 0.20" ESP produces 800 cfm.

Locate 800 cfm (for the 24CWA4) on the Capacity Adjustment Factors on page 270. (TC = 1.00 & SC = 1.00)

Multiply the stated chilled water capacity for the 24CWA4 or the hot water capacity by the adjustment factors to achieve the capacity adjustment.

Propylene Glycol & GPM Adjustment Factors			
Ambient Temp	Propylene Glycol %	Capacity Reduction	GPM Adjustment = 100% Capacity
26° F	10%	x 0.99	x 1.01
20° F	20%	x 0.98	x 1.03
8° F	30%	x 0.98	x 1.07
-5° F	40%	x 0.97	x 1.11
-28° F	50%	x 0.96	x 1.16

Example:

30% Propylene Glycol Solution.

System capacity x 0.98

GPM x 1.07

These specifications are subject to change without notice.

CWA4 Capacity Adjustment Factors

CWA4 CAPACITY CORRECTION FACTORS								
MODEL #	24CWA4		36CWA4		48CWA4		60CWA4	
CFM	TC	SC	TC	SC	TC	SC	TC	SC
625	0.87	0.84						
650	0.89	0.86						
675	0.90	0.88						
700	0.91	0.91						
725	0.94	0.93						
750	0.96	0.96						
775	0.98	0.98						
800	1.00	1.00						
825	1.01	1.01						
850	1.02	1.03						
970			0.81	0.80				
975			0.82	0.81				
1000			0.85	0.84				
1025			0.87	0.86				
1050			0.89	0.88				
1075			0.92	0.91				
1100			0.94	0.93				
1125			0.96	0.95				
1150			0.97	0.97				
1175			0.98	0.98				
1200			1.00	1.00				
1225			1.02	1.03				
1250			1.04	1.05	0.71	0.70		
1270			1.05	1.06	0.72	0.71	0.45	0.43
1275			1.06	1.07	0.73	0.72	0.46	0.44
1300			1.08	1.09	0.75	0.74	0.47	0.45
1325			1.09	1.10	0.77	0.76	0.48	0.46
1350			1.10	1.11	0.79	0.78	0.50	0.48
1360			1.11	1.12	0.81	0.80	0.51	0.49
1375					0.82	0.81	0.52	0.50
1400					0.85	0.84	0.54	0.52
1425					0.87	0.86	0.55	0.53
1450					0.89	0.88	0.56	0.54
1475					0.92	0.91	0.58	0.56
1500					0.94	0.93	0.60	0.58
1525					0.96	0.95	0.62	0.60
1550					0.97	0.97	0.64	0.62
1575					0.98	0.98	0.66	0.64
1600					1.00	1.00	0.67	0.65
1625					1.02	1.03	0.69	0.67
1650					1.04	1.05	0.71	0.70
1675					1.06	1.07	0.73	0.72
1700					1.07	1.08	0.75	0.74
1725					1.08	1.09	0.77	0.76
1750					1.09	1.10	0.79	0.78
1775					1.10	1.11	0.82	0.81
1800					1.11	1.12	0.85	0.84
1825					1.13	1.14	0.87	0.86
1850					1.14	1.15	0.89	0.88
1860					1.15	1.16	0.91	0.90
1875							0.92	0.91
1900							0.94	0.93
1925							0.96	0.95
1950							0.97	0.97
1975							0.98	0.98
2000							1.00	1.00

These specifications are subject to change without notice.

INSTALLATION and OPERATION MANUAL



CWA4
Multiaqua™



INSTALLATION & OPERATING MANUAL

CWA4 Chilled & Hot Water Fan Coil
24,000 – 60,000 BTUH

----- CAUTION -----

Care must be taken when handling sheet metal. Sheet metal parts have sharp edges and could cause injury.

GENERAL

Read the entire contents of this manual before beginning installation. Multiaqua assumes no responsibility for equipment installed contradictory to any code requirement or installation instructions.

The components of this fan coil have been inspected at the factory and readied for shipment. Upon receiving the shipment a visual inspection of the packaging must be performed.

If any damage to the packaging is discovered, an inspection of the components must be performed and noted on the delivery documents. If component damage is found a damage claim must be filed by the receiving party against the delivery party immediately.

This product is designed and manufactured to permit installation in accordance with national codes. It is the installer's responsibility to install the product in accordance with national codes and/or prevailing local codes and regulations.

Care must be taken to ensure the structural integrity of the supporting members, clearances and provisions for servicing, power supply, coil connections and/or condensate removal. Before the installation, ensure the structural strength of the supporting members is sufficient. See figure 1 for hanging weights of the fan coils.

This unit is designed to be installed in a

vertical or horizontal configuration. See figure 2 for fan coil only dimensions. The coil hand of connection is field reversible.

FAN COIL MODEL NUMBER	APPROXIMATED WEIGHTS (LBS)
24CWA4	140
36CWA4	175
48CWA4	189
60CWA4	199

Figure 1



INSTALLATION & OPERATING MANUAL

CWA4 Chilled & Water Fan Coil
24,000 – 60,000 BTUH

Physical Dimensions (in)					
Model Number	A	B	C	D	E
24CWA4	17.50	21.00	39.75	12.50	16.00
36CWA4	17.50	21.00	39.75	12.50	16.00
48CWA4	21.50	25.00	49.75	17.25	19.50
60CWA4	21.50	25.00	49.75	17.25	19.50

Figure 2

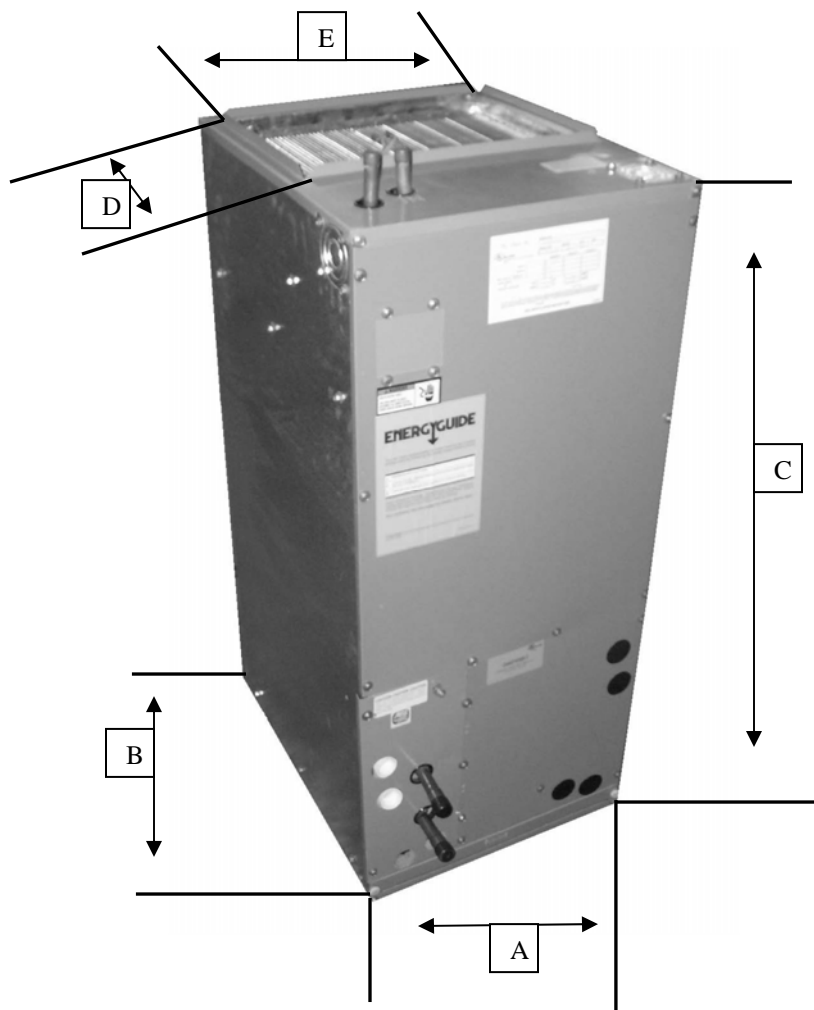



INSTALLATION & OPERATING MANUAL

CWA4 Chilled & Hot Water Fan Coil
24,000 – 60,000 BTUH

----- CAUTION -----

Care must be taken when handling sheet metal. Sheet metal parts have sharp edges and could cause injury.

INSTRUCTIONS FOR INSTALLING FAN COIL

The CWA4 is a chilled and hot water fan coil designed for multi-position applications in closets, attics or basements. They are field convertible to horizontal applications without the need for additional parts. Unit is not suitable for down flow applications.

Figure 3 & 4

CONVERTING FAN COIL TO RIGHT HAND DISCHARGE

The CWA4 fan coil comes shipped from the factory assembled with a left hand air discharge configuration.

1. To convert the fan coil to right hand discharge remove the three front panels.
2. Remove the three screws from the coil mounting brackets and pull entire coil assembly out of the fan coil.

Figure 5



Figure 3

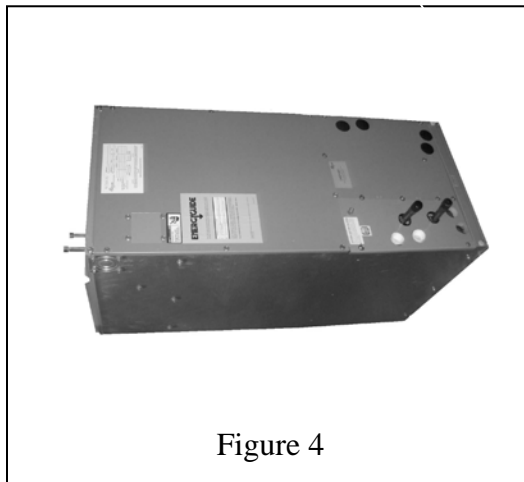

Figure 4

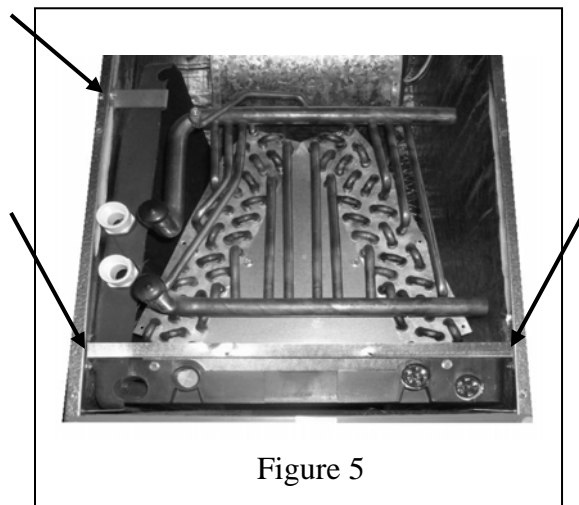

Figure 5



INSTALLATION & OPERATING MANUAL

CWA4 Chilled & Hot Water Fan Coil
24,000 – 60,000 BTUH

3. Remove the horizontal drain pan from the coil and re-install it on the other side.

Figure 6

4. Ensure the coil mounting brackets are secure in order to avoid coil misplacement inside the cabinet. Check coil slope to make sure that the drain pan slopes toward the drain outlet. An incorrectly installed coil could result in damages to the fan coil and property.

5. Re-install the three front panels previously removed in step one.

6. The unit shall be suitable for 0" clearance to combustible materials. Sufficient clearance must be provided at the front of the fan coil to allow access for maintenance and servicing.

7. The fan coil comes with one primary and one secondary condensate drain connection per configuration. Ensure when connecting the field installed condensate drain lines, the lower of the two fan coil drain connections is piped into the buildings condensate removal method.

Figure 7 & 8

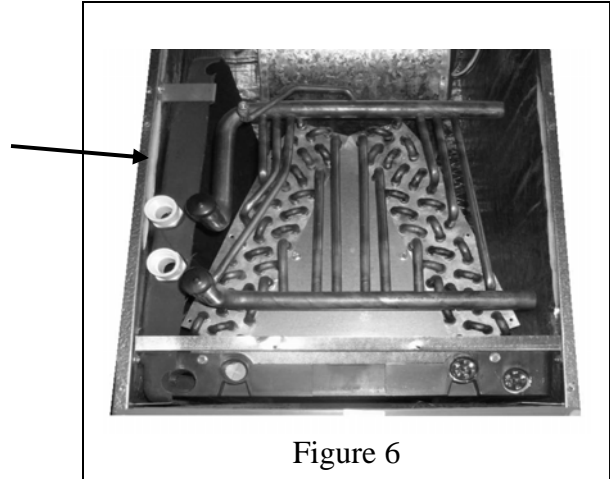

Figure 6

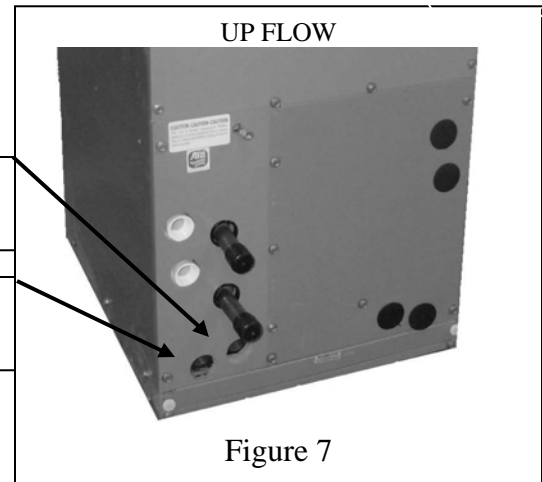

Figure 7

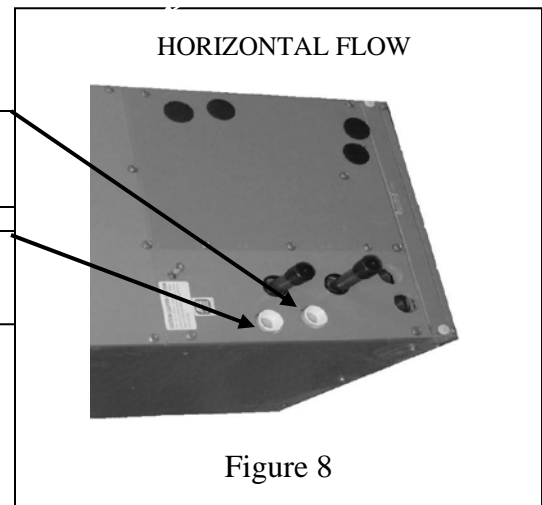

Figure 8



INSTALLATION & OPERATING MANUAL

CWA4 Chilled & Hot Water Fan Coil
24,000 – 60,000 BTUH

8. The hot water coil is a horizontally mounted coil in the top of the fan coil. The hot water inlet is on the right and the outlet on the left. There are two temperature sensors on top of the hot water coil.

Figure 9

9. The CWA4 comes equipped with a circulating pump, coil drain valve, manual air purge fitting and coil temperature sensors.

Figure 10

10. Make sure when attaching ductwork to the fan coil that screws or other objects do not damage the hot water coil. If the coil fins become bent or flattened, ensure that they are straightened so the air flow of the fan coil is not affected.

Figure 11

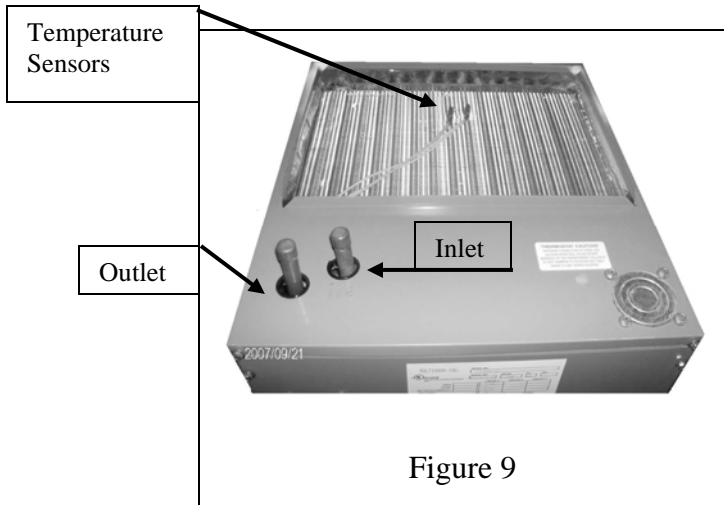

Figure 9

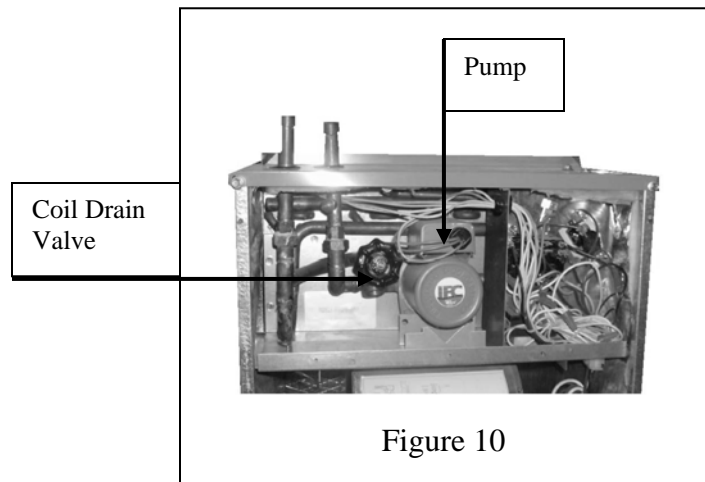

Figure 10

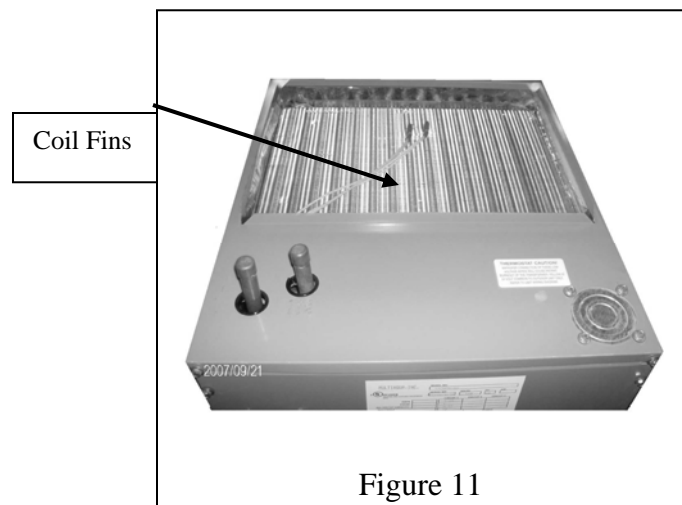

Figure 11



INSTALLATION & OPERATING MANUAL

CWA4 Chilled & Hot Water Fan Coil
24,000 – 60,000 BTUH

11. All duct work must be installed per local and national codes. The return air duct and the return air opening provided in the fan coil must have the same area.

Figure 12 & 13

ELECTRICAL

All wiring must comply with local and national codes. High and low voltage termination points are provided. Knockouts are provided in the cabinet for field wiring of the electrical.

CONTROLS

A 24 vac transformer, fan relay, pump relay and time delay relay are provided inside cabinet. All supplied controls are wired to respective terminations.

Figure 14

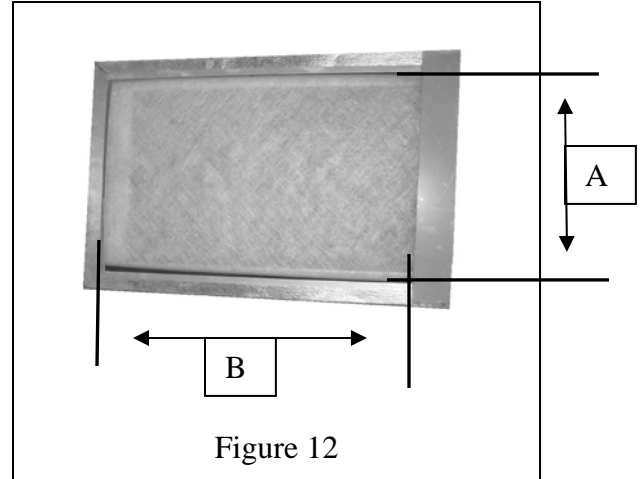
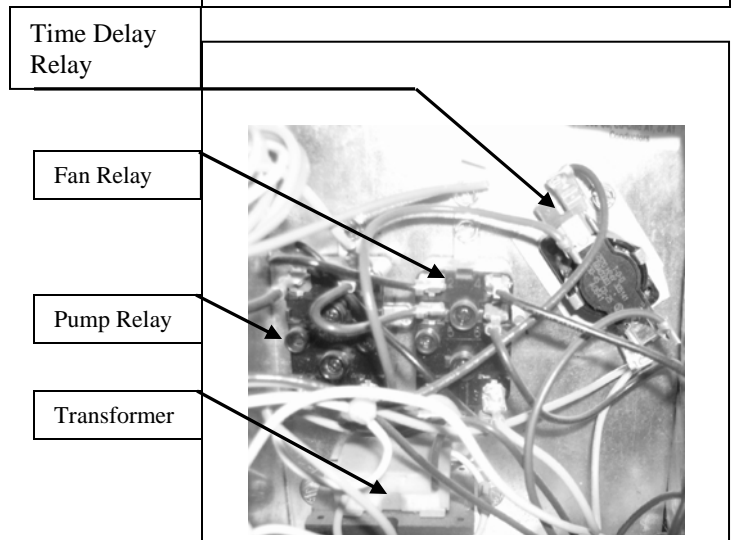

Figure 12

CWA4 Inlet Air Dimensions		
	A	B
24CWA4	15	17.5
36CWA4	15	17.5
48CWA4	19.25	22.25
60CWA4	19.25	22.25

Figure 13



Time Delay Relay

Fan Relay

Pump Relay

Transformer



INSTALLATION & OPERATING MANUAL

CWA4 Chilled & Hot Water Fan Coil
24,000 – 60,000 BTUH

PIPING

12. This fan coil is supplied with one chilled water coil and one hot water coil. Each coil has one dedicated inlet and outlet. Ensure that both lines are insulated according to local and national building codes.

Figure 15

13. Condensate drains must be installed with at least .25" of slope per foot away from the fan coil. Since the drain pan is located on the suction side of the blower a minimum trap of 1.5" must be installed in the drain line for proper drainage.

ROUTINE CHECK UP AND SERVICE

This product is designed to provide many years of dependable, trouble free comfort when properly maintained. Proper maintenance will consist of routine filter cleanings/changes, bi-annual check ups that include but not limited to filter inspections, electric heater inspections /cleaning of the internal electrical and heat transfer components by a qualified service technician. Failure to provide periodic check ups and cleaning can result in excessive operating cost and/or equipment failure.

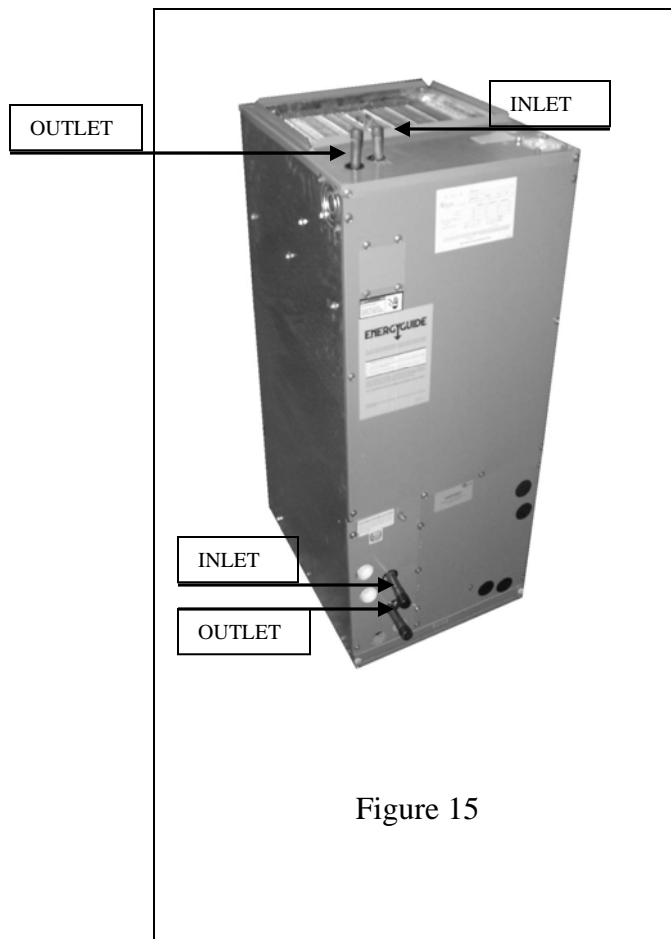
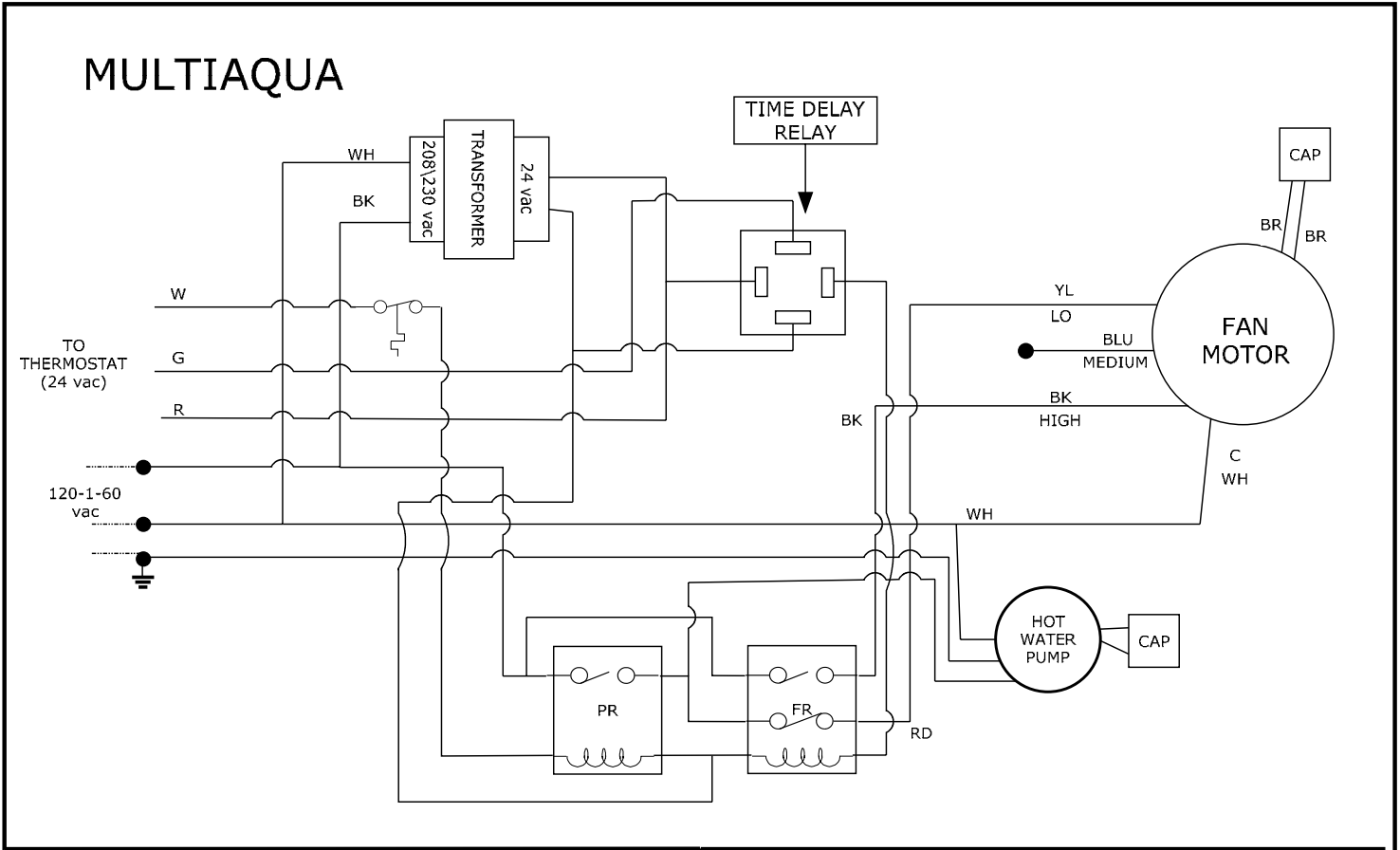

Figure 15

CWA4 Wiring Diagram

120-1-60



TITLE	CWA4 WIRING DIAGRAM			LEGEND:	NOTES:
AUTHOR	kjj			———	FACTORY WIRING
DATE	09/25/07	SHEET	1 OF 1	-----	FIELD WIRING
REVISION	0907300046			PR	PUMP RELAY
				FR	FAN RELAY

CWA4 CERTIFIED DRAWING

CWA4 Certified Drawing
Drawing # 0907400079

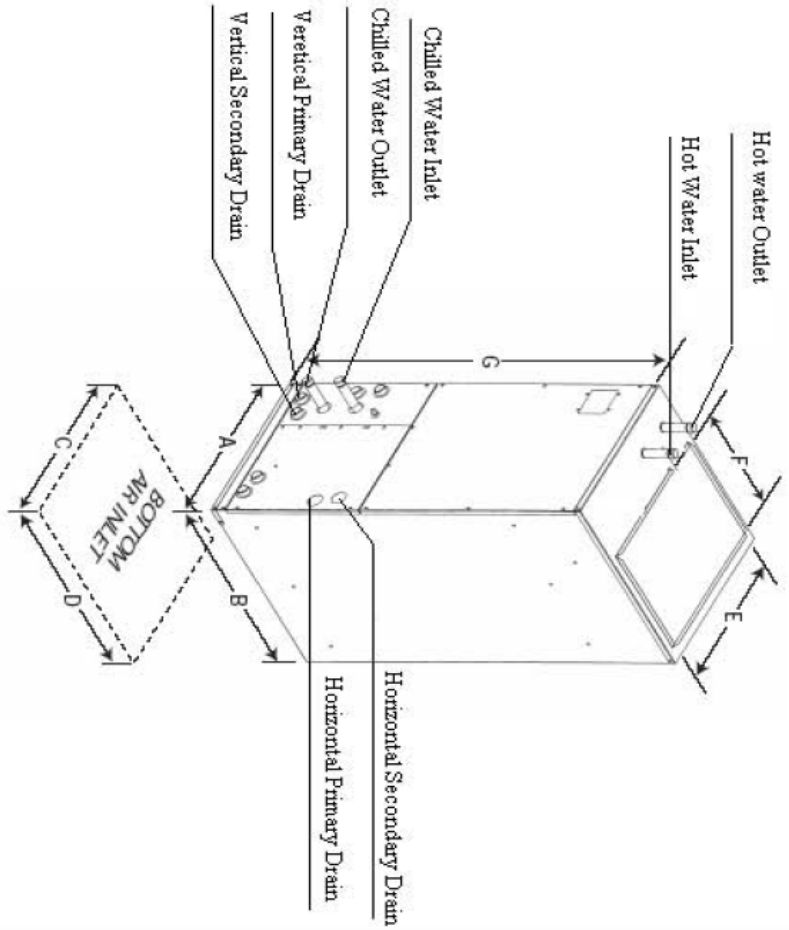

Model No.	A	B	C	D	E	F	G
24CWA4XX	17 1/2	21	15	17 1/2	16	12 1/2	39 1/4
36CWA4XX 48CWA4XX 60CWA4XX	21 1/2	25	19 1/4	22 1/4	19 5/8	17 1/4	49 1/4

Note: "-XX" indicates electric heat (KW) size.