

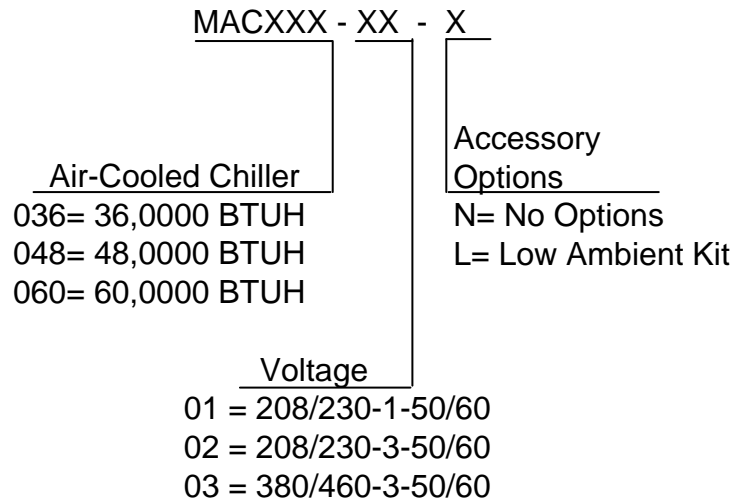

MAC036,048 & 060 Air-Cooled Chiller

Air-Cooled Chillers for Global Residential
and Light Commercial MicroClimates

MAC036,048 & 060 NOMENCLATURE BREAKDOWN



Available Model Numbers		
MAC036-01-N	MAC048-01-N	MAC060-01-N
MAC036-01-L	MAC048-01-L	MAC060-01-L
MAC036-02-N	MAC048-02-N	MAC060-02-N
MAC036-02-L	MAC048-02-L	MAC060-02-L
		MAC060-03-N
		MAC060-03-L

HVAC Guide Specifications

Air-Cooled Liquid Chiller

Nominal Size:

3, 4 & 5 Tons

MultiAqua Model Number:

**MAC036-01-N-407, MAC036-01-L-407: MAC036-02-N-407, MAC036-02-L-407,
MAC048-01-N-407, MAC048-01-L-407: MAC048-02-N-407, MAC048-02-L-407,
MAC060-01-N-407, MAC060-01-L-407, MAC060-02-N-407, MAC060-02-L-407,**

Part 1-General

1.01 System Description

MultiAqua air-cooled liquid chillers are designed using scroll compressors, low sound condenser fans and high efficiency pumps.

1.02 Quality Assurance

- A. Certified in accordance with U.L. Standard 95, latest version (U.S.A.)
- B. Construction shall comply with ASHRAE 15 Safety Code, NEC and ASME applicable codes. (U.S.A. Codes)
- C. Manufactured in a facility registered to ISO 9002, Manufacturing Quality Standard.
- D. ETL Certified
- E. Fully load tested at the factory.
- F. Damage resistant packaging.

1.03 Delivery, Storage and Handling

- A. Packaged and readied for shipment from the factory.
- B. Controls shall be capable of withstanding 150°F storage temperatures in the control compartment.
- C. Stored and handled per manufacturer's recommendations.

Part 2-Product

2.01 Equipment

- A. General:
 1. Unit shall be a factory assembled and tested air-cooled liquid chiller.
 2. Shall be assembled on heavy gauge steel mounting/lifting rails.
 3. Contained within the unit cabinet shall be all factory wiring, piping, controls, refrigerant charge (R407c), POE oil and special accessories required prior to start up.
 4. Brass body strainer with 20 mesh screen and blow down shall be supplied in cabinet as a field installable accessory.
- B. Unit Cabinet:
 1. Composed of heavy gauge galvanized steel casing with a baked polyester powder.
 2. Capable of withstanding 500-hour salt spray test in accordance with the ASTM (USA) standard.
- C. Condenser Fans:
 1. 4-blade, aluminum construction and shall be dynamically balanced and corrosion resistant.
 2. Horizontal discharged air.
 3. Motors and blades shall be protected by coated steel wire safety guards.
- D. Fan Motors:
 1. Condenser fan motors shall be single speed, direct drive.
 2. Totally enclosed.
 3. Permanently lubricated sleeve bearings and Class F insulation.
 4. Internal overload protection.
- E. Compressors:
 1. Unit shall contain one fully hermetic scroll compressors.
 2. Direct-drive, 3500 rpm (60Hz)
 3. Compressor motor shall be suction gas cooled.
 4. Internal motor protection.
 5. Externally protected by low and high pressure cutout devices.
 6. Individual vibration isolators.

- F. Pump:
 1. Circulating pump shall be stainless steel with high efficiency enclosed motor.
 2. Unit shall have chilled liquid solution piping to the exterior of the cabinet.

- G. Evaporator:
 1. Evaporator shall have one independent refrigerant circuit and one liquid solution circuit.
 2. Rated for a refrigerant side working pressure of 450 psig and a maximum water side working pressure of 150 psig.
 3. Single pass, ANSI type 316 stainless steel, brazed plate construction.
 4. Externally insulated with closed cell, elastomeric foam. (ASTM518)

- H. Condenser:
 1. Condenser coil shall be air-cooled with integral subcooler.
 2. One independent refrigerant circuit.
 3. Constructed of rifled copper tubing mechanically bonded to aluminum fins.
 4. Cleaned and dehydrated.
 5. Factory leak tested to 450 psig.

- I. Refrigerant Circuits:
 1. Each circuit shall contain a sight glass, liquid line filter, thermal expansion valve, refrigerant charge of R407c and POE compressor oil.

Part 3-Controls and Safeties

3.01 Controls

- A. Chiller shall be completely factory wired and tested.
- B. Capacity control shall be based on leaving chilled liquid solution temperature.
 1. Temperature accuracy shall be + - 1.0°F.
 2. Controls shall be capable of staging the two compressors.
- C. Controls shall include the following components.
 1. 24vac transformer to serve all controllers relays and control components.
 2. Microprocessor based liquid solution temperature controller.
 3. Leaving water temperature thermistor.
 4. Pump bypass timer.
 5. Compressor recycle timer.
 6. Optional low pressure bypass timer for low ambient operation.
 7. Optional fan cycling control for low ambient operation.
 8. Chilled liquid solution flow switch.

3.02 Safeties

- A. Unit shall be equipped with thermistors and all necessary components in conjunction with the control system to provide the following protectants.
 1. Low refrigerant pressure.
 2. High refrigerant pressure.
 3. Low chilled liquid solution temperature.
 4. Low chilled liquid solution flow.
 5. Thermal overload.
 6. Short cycling.

Part 4-Operating Characteristics:

4.01 Temperatures

- A. Unit shall be capable of starting and running at outdoor temperatures from 55°F to 120°F.
- B. Optional Low Ambient Kit shall allow starting and running at outdoor temperatures to -20°F. A field supplied and installed crankcase heater must be used when operating at these temperatures.
- C. Unit shall be capable of starting up with a maximum 80°F and a sustained 70°F entering fluid solution temperature to the evaporator.
- D. Minimum 10% Glycol solution is required. For outdoor temperatures below 32°F, reference MAC Glycol Solution Data table.

4.02 Electrical Requirements

- A. Primary electrical power supply shall enter the unit at a single location.
- B. Electrical power supply shall be rated to withstand 120°F operating ambient temperature.
- C. Units shall be available in 1 or 3-phase power at the voltages shown in the equipment electrical data.
- D. Control points shall be accessed through terminal block.

MAC036, 048 & 060 Product Specifications

Physical Data										
Model Number	Coil				Chiller				Weight (lbs)	
	Height (in)	Length (in)	Copper Diameter (in)	Coil Rows	Height (in)	Length (in)	Width (in)	Refrigerant R407c	Net	Shipping
MAC036	38	48	3/8	1	49.75	39.75	16.25	84.66 oz	280	283
MAC048	38	48	3/8	2	49.75	39.75	16.25	92.95 oz	292	295
MAC060	38	48	3/8	2	49.75	39.75	16.25	92.95 oz	313	316

Electrical Data										
Model Number	Volts/ Phase/ Hertz	Compressor		Condenser Fan Motor (2 qty)		Pump Motor		Fuse or HACR Circuit Breaker Per Circuit		
		(RLA)	(LRA)	(FLA)	(RPM)	(FLA)	(RPM)	Minimum Amps	Maximum Amps	
MAC036-01	208/230-1-50/60	18.4	95	1.05	1050	3.70	3450	28.80	45	
MAC036-02	208/230-3-50/60	11.4	77	1.05	1050	3.70	3450	20.05	30	
MAC048-01	208/230-1-50/60	22.1	137	1.05	1050	3.70	3450	33.43	50	
MAC048-02	208/230-3-50/60	16.4	91	1.05	1050	3.70	3450	26.30	40	
MAC060-01	208/230-1-50/60	32.1	169	1.05	1050	3.70	3450	45.93	70	
MAC060-02	208/230-3-50/60	19.3	137	1.05	1050	3.70	3450	29.93	45	
MAC060-03	380/460-3-50/60	10	75	0.60	1050	2.85	3500	16.55	25	

	MAC036	MAC048	MAC060
Compressor	Copeland Scroll	Copeland Scroll	Copeland Scroll
Refrigerant	R407c	R407c	R407c
Heat Exchanger	Brazed Plate	Brazed Plate	Brazed Plate
Max. Head Pressure	50 ft.	50 ft.	50 ft.
Max Flow Rate	8.6 gpm	11.5 gpm	14.4 gpm
Min Flow Rate	5.5 gpm	6.5 gpm	9.0 gpm
Supply Water Temp	44°	44°	44°
Return Water Temp	54°	54°	54°
Min. Solution Content	25 Gallons	25 Gallons	25 Gallons
Expansion Tank Size	2 Gallons	2 Gallons	2 Gallons
Pump	0.5 HP	0.5 HP	0.5 HP
Water Connections	1" S & 1.25" R	1" S & 1.25" R	1" S & 1.25" R
Internal Pressure loss	1.77 ft of head	1.68 ft of head	1.85 ft of head

Copper Wire Size (1% Voltage Drop)									
Supply Wire Length in Feet	200	6	4	4	4	3	3	2	2
	150	8	6	6	4	4	4	4	3
100	10	8	8	6	6	6	6	4	4
50	14	12	10	10	8	8	8	6	6
	15	20	25	30	35	40	45	45	50
Supply Circuit Ampacity									

Multi aqua chillers are designed to operate exclusively with R407c refrigerant in a self-contained, pre-charged refrigerant system. Do not access the closed refrigerant circuit for any reason other than after-sale, after installation component replacement. Routine maintenance and service is to be performed by qualified personnel only.

These specifications are subject to change without notice.

MAC036, 048 & 060 Product Specifications

MAC036, 048 & 060 Capacity / Watts / EER									
O/A Temp (°F)	MAC036			MAC048			MAC060		
	Tons	KW	EER	Tons	KW	EER	Tons	KW	EER
82	2.9	3.3	10.55	3.9	4.3	10.88	5.1	5.3	11.55
95	2.8	3.7	9.08	3.7	4.6	9.65	4.9	5.9	9.97
100	2.7	3.9	8.31	3.6	4.8	9.00	4.8	6.1	9.44
105	2.7	4.0	8.10	3.5	5.0	8.40	4.7	6.4	8.81
110	2.6	4.3	7.28	3.4	5.4	7.56	4.7	6.5	8.68

Glycol Solution Data				
Propylene Glycol %	Water Flow	Capacity	Min. Ambient Temp	GPM Adjustment= 100% Capacity
10%	x 1.020	x 0.99	26°F	x 1.01
20%	x 1.028	x 0.98	18°F	x 1.03
30%	x 1.036	x 0.98	8°F	x 1.07
40%	x 1.048	x 0.97	-7°F	x 1.11
50%	x 1.057	x 0.96	-29°F	x 1.16

Example: 30% glycol solution.

Maximum Flow Rate = 12gpm x 1.036

System capacity x .98

Use Propylene Glycol Only

Important

If the outside temperature is expected to fall below freezing (32°F) in the area the Multiaqua chiller is to be installed; the installer must take the following precautions. Failure to do so will void the warranty.

To not engage in cold ambient mitigation will result in the failure of components such as the heat exchanger, piping, circulating pump, etc... and or property damage.

- Keep the liquid solution at a minimum of ten percent propylene glycol even in areas where there is no danger of freezing.
- The percentage amount of glycol recommended is dependent on the expected ambient temperatures and the solution makeup recommendation of the glycol manufacturer. Refer to the Glycol Solution Data table above.
- Ensure the system circulating pump is in a constant energized mode to keep a continuous circulation of liquid solution.

The Multiaqua chiller is a self-contained air-cooled condenser, coupled with an insulated brazed plate heat exchanger (evaporator). The system utilizes a scroll compressor to circulate refrigerant between the condenser and heat exchanger. The refrigerant is metered into the heat exchanger with a thermostatic expansion valve. Protecting the system are high and low pressure switches as well as a pump flow switch.

Liquid solution (water and propylene glycol; minimum 10 % is required) is circulated through the heat exchanger by an externally mounted pump. The liquid solution flows through the heat exchanger to the system supply piping and on to the air handlers.

Low ambient kits are available for operating ambient temperatures down to 0 degrees Fahrenheit. The low ambient kits consist of an ICM 325 (+) ICM (175) for single and three phase 208/230 vac chillers. For the three phase 380/460 vac chillers a pressure activated fan control is used.

These specifications are subject to change without notice.

MAC036 Cooling Performance Data

MAC036 CAPACITIES with 0% Glycol										
LWT (°F)	ENTERING AIR TEMPERATURE (°F)									
	82		95		100		105		110	
	TONS	GPM	TONS	GPM	TONS	GPM	TONS	GPM	TONS	GPM
35	1.70	7.2	1.60	7.2	1.50	7.2	1.40	7.2	1.30	7.2
40	2.30		2.20		2.10		2.10			
42	2.60		2.50		2.40		2.40			
44	2.90		2.80		2.70		2.70			
45	3.10		3.00		2.90		2.80			
46	3.20		3.10		3.00		3.00			
48	3.60		3.50		3.20		3.30			
50	3.90		3.80		3.50		3.60			
55	4.80		4.70		4.30		4.30			
60	5.80		5.60		5.20		5.20			

MAC036 CAPACITIES with 10% Glycol										
LWT (°F)	ENTERING AIR TEMPERATURE (°F)									
	82		95		100		105		110	
	TONS	GPM	TONS	GPM	TONS	GPM	TONS	GPM	TONS	GPM
35	1.68	7.2	1.58	7.2	1.49	7.2	1.39	7.2	1.29	7.2
40	2.28		2.18		2.08		2.08			
42	2.57		2.48		2.38		2.38			
44	2.87		2.77		2.67		2.67			
45	3.07		2.97		2.87		2.77			
46	3.17		3.07		2.97		2.97			
48	3.56		3.47		3.17		3.27			
50	3.86		3.76		3.47		3.56			
55	4.75		4.65		4.26		4.26			
60	5.74		5.54		5.15		5.15			

MAC036 CAPACITIES with 20% Glycol										
LWT (°F)	ENTERING AIR TEMPERATURE (°F)									
	82		95		100		105		110	
	TONS	GPM	TONS	GPM	TONS	GPM	TONS	GPM	TONS	GPM
35	1.67	7.2	1.57	7.2	1.47	7.2	1.37	7.2	1.27	7.2
40	2.25		2.16		2.06		2.06			
42	2.55		2.45		2.35		2.35			
44	2.84		2.74		2.65		2.65			
45	3.04		2.94		2.84		2.74			
46	3.14		3.04		2.94		2.94			
48	3.53		3.43		3.14		3.23			
50	3.82		3.72		3.43		3.53			
55	4.70		4.61		4.21		4.21			
60	5.68		5.49		5.10		5.10			

These specifications are subject to change without notice.

MAC036 Cooling Performance Data

MAC036 CAPACITIES with 30% Glycol										
LWT (°F)	ENTERING AIR TEMPERATURE (°F)									
	82		95		100		105		110	
	TONS	GPM	TONS	GPM	TONS	GPM	TONS	GPM	TONS	GPM
35	1.67	7.2	1.57	7.2	1.47	7.2	1.37	7.2	1.27	7.2
40	2.25		2.16		2.06		2.06		1.96	
42	2.55		2.45		2.35		2.35		2.25	
44	2.84		2.74		2.65		2.65		2.55	
45	3.04		2.94		2.84		2.74		2.65	
46	3.14		3.04		2.94		2.94		2.84	
48	3.53		3.43		3.14		3.23		3.14	
50	3.82		3.72		3.43		3.53		3.43	
55	4.70		4.61		4.21		4.21		4.12	
60	5.68		5.49		5.10		5.10		4.90	

MAC036 CAPACITIES with 40% Glycol										
LWT (°F)	ENTERING AIR TEMPERATURE (°F)									
	82		95		100		105		110	
	TONS	GPM	TONS	GPM	TONS	GPM	TONS	GPM	TONS	GPM
35	1.65	7.2	1.55	7.2	1.46	7.2	1.36	7.2	1.26	7.2
40	2.23		2.13		2.04		2.04		1.94	
42	2.52		2.43		2.33		2.33		2.23	
44	2.81		2.72		2.62		2.62		2.52	
45	3.01		2.91		2.81		2.72		2.62	
46	3.10		3.01		2.91		2.91		2.81	
48	3.49		3.40		3.10		3.20		3.10	
50	3.78		3.69		3.40		3.49		3.40	
55	4.66		4.56		4.17		4.17		4.07	
60	5.63		5.43		5.04		5.04		4.85	

MAC036 CAPACITIES with 50% Glycol										
LWT (°F)	ENTERING AIR TEMPERATURE (°F)									
	82		95		100		105		110	
	TONS	GPM	TONS	GPM	TONS	GPM	TONS	GPM	TONS	GPM
35	1.63	7.2	1.54	7.2	1.44	7.2	1.34	7.2	1.25	7.2
40	2.21		2.11		2.02		2.02		1.92	
42	2.50		2.40		2.30		2.30		2.21	
44	2.78		2.69		2.59		2.59		2.50	
45	2.98		2.88		2.78		2.69		2.59	
46	3.07		2.98		2.88		2.88		2.78	
48	3.46		3.36		3.07		3.17		3.07	
50	3.74		3.65		3.36		3.46		3.36	
55	4.61		4.51		4.13		4.13		4.03	
60	5.57		5.38		4.99		4.99		4.80	

These specifications are subject to change without notice.

MAC048 Cooling Performance Data

MAC048 CAPACITIES with 0% Glycol										
LWT (°F)	ENTERING AIR TEMPERATURE (°F)									
	82		95		100		105		110	
	TONS	GPM	TONS	GPM	TONS	GPM	TONS	GPM	TONS	GPM
35	2.70	9.6	2.50	9.6	2.40	9.6	2.30	9.6	2.30	9.6
40	3.30		3.10		3.00		2.90			
42	3.60		3.40		3.30		3.20			
44	3.90		3.70		3.60		3.50			
45	4.10		3.90		3.80		3.60			
46	4.20		4.00		3.90		3.80			
48	4.50		4.30		4.20		4.10			
50	4.80		4.60		4.50		4.40			
55	5.70		5.40		5.20		5.20			
60	6.60		6.20		6.10		6.10			

MAC048 CAPACITIES with 10% Glycol										
LWT (°F)	ENTERING AIR TEMPERATURE (°F)									
	82		95		100		105		110	
	TONS	GPM	TONS	GPM	TONS	GPM	TONS	GPM	TONS	GPM
35	2.67	9.6	2.48	9.6	2.38	9.6	2.28	9.6	2.28	9.6
40	3.27		3.07		2.97		2.87			
42	3.56		3.37		3.27		3.17			
44	3.86		3.66		3.56		3.47			
45	4.06		3.86		3.76		3.56			
46	4.16		3.96		3.86		3.76			
48	4.46		4.26		4.16		4.06			
50	4.75		4.55		4.46		4.36			
55	5.64		5.35		5.15		5.15			
60	6.53		6.14		6.04		6.04			

MAC048 CAPACITIES with 20% Glycol										
LWT (°F)	ENTERING AIR TEMPERATURE (°F)									
	82		95		100		105		110	
	TONS	GPM	TONS	GPM	TONS	GPM	TONS	GPM	TONS	GPM
35	2.65	9.6	2.45	9.6	2.35	9.6	2.25	9.6	2.25	9.6
40	3.23		3.04		2.94		2.84			
42	3.53		3.33		3.23		3.14			
44	3.82		3.63		3.53		3.43			
45	4.02		3.82		3.72		3.53			
46	4.12		3.92		3.82		3.72			
48	4.41		4.21		4.12		4.02			
50	4.70		4.51		4.41		4.31			
55	5.59		5.29		5.10		5.10			
60	6.47		6.08		5.98		5.98			

These specifications are subject to change without notice.

MAC048 Cooling Performance Data

MAC048 CAPACITIES with 30% Glycol										
LWT (°F)	ENTERING AIR TEMPERATURE (°F)									
	82		95		100		105		110	
	TONS	GPM	TONS	GPM	TONS	GPM	TONS	GPM	TONS	GPM
35	2.65	9.6	2.45	9.6	2.35	9.6	2.25	9.6	2.25	9.6
40	3.23		3.04		2.94		2.84			
42	3.53		3.33		3.23		3.14			
44	3.82		3.63		3.53		3.43			
45	4.02		3.82		3.72		3.53			
46	4.12		3.92		3.82		3.72			
48	4.41		4.21		4.12		4.02			
50	4.70		4.51		4.41		4.31			
55	5.59		5.29		5.10		5.10			
60	6.47		6.08		5.98		5.98			

MAC048 CAPACITIES with 40% Glycol										
LWT (°F)	ENTERING AIR TEMPERATURE (°F)									
	82		95		100		105		110	
	TONS	GPM	TONS	GPM	TONS	GPM	TONS	GPM	TONS	GPM
35	2.62	9.6	2.43	9.6	2.33	9.6	2.23	9.6	2.23	9.6
40	3.20		3.01		2.91		2.81			
42	3.49		3.30		3.20		3.10			
44	3.78		3.59		3.49		3.40			
45	3.98		3.78		3.69		3.49			
46	4.07		3.88		3.78		3.69			
48	4.37		4.17		4.07		3.98			
50	4.66		4.46		4.37		4.27			
55	5.53		5.24		5.04		5.04			
60	6.40		6.01		5.92		5.92			

MAC048 CAPACITIES with 50% Glycol										
LWT (°F)	ENTERING AIR TEMPERATURE (°F)									
	82		95		100		105		110	
	TONS	GPM	TONS	GPM	TONS	GPM	TONS	GPM	TONS	GPM
35	2.59	9.6	2.40	9.6	2.30	9.6	2.21	9.6	2.21	9.6
40	3.17		2.98		2.88		2.78			
42	3.46		3.26		3.17		3.07			
44	3.74		3.55		3.46		3.36			
45	3.94		3.74		3.65		3.46			
46	4.03		3.84		3.74		3.65			
48	4.32		4.13		4.03		3.94			
50	4.61		4.42		4.32		4.22			
55	5.47		5.18		4.99		4.99			
60	6.34		5.95		5.86		5.86			

These specifications are subject to change without notice.

MAC060 Cooling Performance Data

MAC060 CAPACITIES with 0% Glycol										
LWT (°F)	ENTERING AIR TEMPERATURE (°F)									
	82		95		100		105		110	
	TONS	GPM	TONS	GPM	TONS	GPM	TONS	GPM	TONS	GPM
35	3.90	12.0	3.70	12.0	3.60	12.0	3.50	12.0	3.50	12.0
40	4.50		4.30		4.20		4.10			
42	4.80		4.60		4.50		4.30			
44	5.10		4.90		4.80		4.70			
45	5.30		5.10		5.00		4.80			
46	5.40		5.20		5.10		5.00			
48	5.80		5.60		5.40		5.30			
50	6.10		5.90		5.70		5.60			
55	7.00		6.70		6.40		6.30			
60	7.80		7.50		7.30		7.10			

MAC060 CAPACITIES with 10% Glycol										
LWT (°F)	ENTERING AIR TEMPERATURE (°F)									
	82		95		100		105		110	
	TONS	GPM	TONS	GPM	TONS	GPM	TONS	GPM	TONS	GPM
35	3.86	12.0	3.66	12.0	3.56	12.0	3.47	12.0	3.47	12.0
40	4.46		4.26		4.16		4.06			
42	4.75		4.55		4.46		4.26			
44	5.05		4.85		4.75		4.65			
45	5.25		5.05		4.95		4.75			
46	5.35		5.15		5.05		4.95			
48	5.74		5.54		5.35		5.25			
50	6.04		5.84		5.64		5.54			
55	6.93		6.63		6.34		6.24			
60	7.72		7.43		7.23		7.03			

MAC060 CAPACITIES with 20% Glycol										
LWT (°F)	ENTERING AIR TEMPERATURE (°F)									
	82		95		100		105		110	
	TONS	GPM	TONS	GPM	TONS	GPM	TONS	GPM	TONS	GPM
35	3.82	12.0	3.63	12.0	3.53	12.0	3.43	12.0	3.43	12.0
40	4.41		4.21		4.12		4.02			
42	4.70		4.51		4.41		4.21			
44	5.00		4.80		4.70		4.61			
45	5.19		5.00		4.90		4.70			
46	5.29		5.10		5.00		4.90			
48	5.68		5.49		5.29		5.19			
50	5.98		5.78		5.59		5.49			
55	6.86		6.57		6.27		6.17			
60	7.64		7.35		7.15		6.96			

These specifications are subject to change without notice.

MAC060 Cooling Performance Data

MAC060 CAPACITIES with 30% Glycol										
LWT (°F)	ENTERING AIR TEMPERATURE (°F)									
	82		95		100		105		110	
	TONS	GPM	TONS	GPM	TONS	GPM	TONS	GPM	TONS	GPM
35	3.82	12.0	3.63	12.0	3.53	12.0	3.43	12.0	3.43	12.0
40	4.41		4.21		4.12		4.02			
42	4.70		4.51		4.41		4.21		4.31	
44	5.00		4.80		4.70		4.61		4.61	
45	5.19		5.00		4.90		4.70		4.70	
46	5.29		5.10		5.00		4.90		4.90	
48	5.68		5.49		5.29		5.19		5.19	
50	5.98		5.78		5.59		5.49		5.49	
55	6.86		6.57		6.27		6.17		6.08	
60	7.64		7.35		7.15		6.96		6.86	

MAC060 CAPACITIES with 40% Glycol										
LWT (°F)	ENTERING AIR TEMPERATURE (°F)									
	82		95		100		105		110	
	TONS	GPM	TONS	GPM	TONS	GPM	TONS	GPM	TONS	GPM
35	3.78	12.0	3.59	12.0	3.49	12.0	3.40	12.0	3.40	12.0
40	4.37		4.17		4.07		3.98		3.98	
42	4.66		4.46		4.37		4.17		4.27	
44	4.95		4.75		4.66		4.56		4.56	
45	5.14		4.95		4.85		4.66		4.66	
46	5.24		5.04		4.95		4.85		4.85	
48	5.63		5.43		5.24		5.14		5.14	
50	5.92		5.72		5.53		5.43		5.43	
55	6.79		6.50		6.21		6.11		6.01	
60	7.57		7.28		7.08		6.89		6.79	

MAC060 CAPACITIES with 50% Glycol										
LWT (°F)	ENTERING AIR TEMPERATURE (°F)									
	82		95		100		105		110	
	TONS	GPM	TONS	GPM	TONS	GPM	TONS	GPM	TONS	GPM
35	3.74	12.0	3.55	12.0	3.46	12.0	3.36	12.0	3.36	12.0
40	4.32		4.13		4.03		3.94		3.94	
42	4.61		4.42		4.32		4.13		4.22	
44	4.90		4.70		4.61		4.51		4.51	
45	5.09		4.90		4.80		4.61		4.61	
46	5.18		4.99		4.90		4.80		4.80	
48	5.57		5.38		5.18		5.09		5.09	
50	5.86		5.66		5.47		5.38		5.38	
55	6.72		6.43		6.14		6.05		5.95	
60	7.49		7.20		7.01		6.82		6.72	

These specifications are subject to change without notice.

MAC 036, 048 & 060 Chiller Pump Curve

Pump Model Numbers
 SSP-1 = 208/230-1-50/60
 SSP-2 = 208/230/460-3-50/60
 0.5 Horsepower

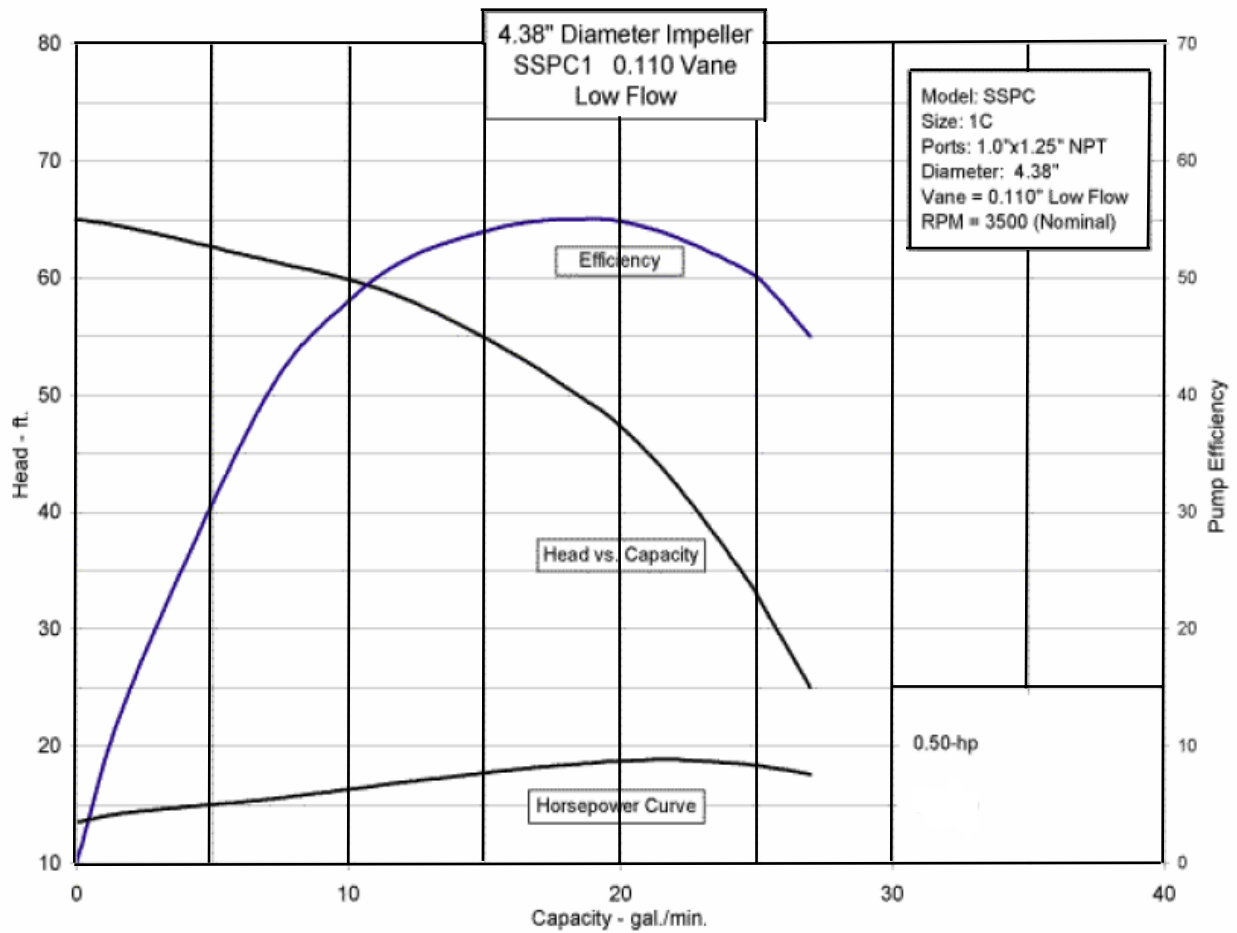

INSTALLATION and OPERATION MANUAL



MAC036, 048 & 060



Table of Contents

	Page
<u>Introduction</u>	59
<u>System Description & Sequence of Operation</u>	60
<u>Electrical & Physical Data</u>	61
<u>Description of Electrical Controls</u>	63
<u>Chiller Controls Sequence of Operation</u>	65
<u>Refrigeration System Operation</u>	66
<u>Description of Refrigeration Components</u>	66
<u>Piping System Components</u>	68
<u>Layout & Design</u>	69
<u>Banked Chiller Configuration</u>	69
<u>Installation Notes</u>	71
<u>Propylene Glycol Content</u>	72
<u>Expansion Tank</u>	72
<u>Filling the System with Propylene Glycol</u>	73
<u>Air Elimination</u>	73

Multiagua Chiller Manual

The Multiagua Chiller System is the only air conditioning/refrigeration system of its kind in the world today offering the degree application flexibility described in the following manual.

The Multiagua Chiller System is not only unique in its application flexibility; it is unique in superior quality, rated capacities and rugged durability. When installed in accordance with these instructions the system will deliver years of trouble free service.

Proper equipment sizing, piping design and installation are critical to the performance of the chiller. This manual is meant to be a “how to” introduction to piping and installing the Multiagua Chiller System.

MAC036, 048 & 060 Chiller Features

- Copeland Scroll Compressors
 - Stainless Steel Pump
- Advanced Motor Protection
 - Loss of Flow Protection
- Control Power Transformer
 - Low Ambient Option
- Integrated Chilled Solution Pump Control
 - Flow Switch
 - Strainer Connection Kit
- Painted Metal Condenser Protector Grille
- Single Refrigeration Circuits and Single Liquid Solution Circuit



RECOGNIZE THIS SYMBOL AS AN INDICATION OF IMPORTANT SAFETY OR INSTRUCTION RELATED INFORMATION.

Web site information addresses are supplied throughout this manual for piping and accessory information. The plumbing industry also has pressure drop information on ferrous and copper piping systems.

The following sections will describe each component and how it functions within the system. Installation information is supplied where appropriate. The piping design section will explain the design and layout the piping system from a “how to” perspective. Following the examples provided will enable the installer to determine the correct pipe and accessory sizing, as well as equipment location. It is important to know before installation if the proposed system will operate correctly and by doing a formal layout of a new application or review of an existing piping system will make that determination.

Throughout this manual the term “liquid solution” is used in place of water. The chiller circulates a solution of water and Propylene Glycol.



It is essential to operate the system with a minimum of 10% glycol. **DO NOT OPERATE THIS SYSTEM USING WATER ALONE.**

For proper liquid solutions mix ratios, refer to table 6, page 72 or the glycol manufacture’s recommended mix ratios.

System Description & Sequence of Operation



The Multiaqua Chiller is a self-contained, air-cooled condenser, coupled with an insulated brazed plate heat exchanger (evaporator). The system utilizes a scroll compressor to circulate refrigerant between the condenser and heat exchanger. The refrigerant is metered into the heat exchanger with a thermostatic expansion valve. Protecting the system are high and low pressure switches as well as a pump flow switch.

Liquid solution (water and propylene glycol) is circulated through the heat exchanger by a factory supplied internal pump. The liquid solution flows through the heat exchanger to the system supply piping and on to the air handlers.

A solenoid-operated, motorized valve or circulator controls the flow of the chilled liquid solution through the air handlers. The valves or circulators can be actuated by a variety of different control schemes.

Liquid solution temperature is controlled by a chiller mounted digital electronic controls. A system sequence of operation, individual control description, troubleshooting information and a schematic are included in the controls section.



It must be recognized that ferrous pipe may cause acceleration deterioration of the brazed plate heat exchanger and could void the heat exchanger warranty.

Cooling Diversity Load

Equipment sizing for a chilled liquid solution system can utilize Cooling Load Diversity. Diversity is described as the actual amount of cooling needed (heat load) by various sections of a structure at a given time. Conventional air conditioning systems are designed for the highest structure heat load. The conventional system determines and selects equipment based on the peak heat load demanded by the structure. A system sized to take advantage of diversity would determine the heat load by the time of day, building exposure and usage. As an example the sections of a structure facing west, demand more cooling in the afternoon, than sections facing east. The opposite of this is true in the morning, where the east section is exposed to a higher heat load requiring more cooling. Utilizing diversity the chiller system would adapt to the needs of each side of the structure during peak demand by delivering more cooling to that area and less to the areas that do not need it. A structure utilizing a conventional DX system, requires 8 tons of cooling at peak load, could utilize a much smaller capacity system (potentially 4 or 5 tons) if the system installed could take advantage of load diversity, which would supply the necessary amount of cooling to the space, as and when needed instead of keeping a larger capacity available at all times.

Cooling load diversity can best be determined by referring to ACCA. (Air Conditioning Contractors of America) Manual "J", Refer to the appendix A-2, Multi-Zone Systems. ACCA's Internet address is <http://www.acca.org/>

Because of diversity a Multiaqua Chiller can serve more total air handler tonnage than chiller capacity. For example, a 5-ton chiller may be delivering chilled liquid solution to 7 or more tons of air handler capacity. Because of cooling load diversity, the building does not need equal amounts of cooling in each area at the same time.

ELECTRICAL AND PHYSICAL DATA

The information contained in this manual has been prepared to assist in the proper installation, operation and maintenance of the chiller. Improper installation, or installation not made in accordance with these instructions can result in unsatisfactory operation and/or dangerous conditions and can cause the related warranty not to apply.

Read this manual and any instructions packaged with separate equipment required to make up the system prior to installation. Retain this manual for future reference.



Separate and independent power supplies and disconnects must be provided. These chillers have separate and discreet power requirements within one cabinet.



All power to the chiller must be turned off prior to opening cabinet and or servicing.



Failure to properly ground chiller can result in death.



Disconnect all power wiring to chiller before maintenance or service work. Failure to do so can cause electrical shock resulting in personal injury or death.



All wiring must be done in accordance with the NEC (National Electric Code) as well as state and local codes, by qualified electricians.



Product warranty does not cover any damages or defect to the chiller caused by the attachment or use of any components, accessories or devices (other than those authorized by the manufacturer) into, onto or in conjunction with the chiller. You should be aware that the use of unauthorized components, accessories or devices may adversely affect the operation of the chiller and may also endanger life and property. The manufacturer disclaims any responsibility for such loss or injury resulting from the use of such unauthorized components, accessories or devices.



Upon receiving the chiller and components, inspect for any shipping damage. Claims for damage, either apparent or concealed should be filed immediately with the shipping company.



No liquid other than the solution of water and propylene glycol (mixed in accordance with table 6) shall be used in the piping system.



Corrosive environments may subject metal parts of the chiller to rust and deteriorate. The oxidation could shorten the chiller's useful life. Corrosive elements include salt spray, fog or mist in sea coastal areas, sulfur or chlorine from lawn watering systems and various chemical contaminants from industries such as paper mills and petroleum refineries.

If the unit is to be installed in an area where contaminates are likely to be a problem, special attention should be given to the equipment location and exposure.

- Avoid having lawn sprinklers spray directly on the chiller cabinet.
- In coastal areas, locate the chiller on the side of the building away from the water front.
- Elevating the chiller off of its slab or base enough to allow air circulation will help avoid holding water in contact with the cabinet base.
- Regular maintenance will reduce the build-up of contaminants and help protect the cabinet finish.
- In severe locations having the chiller coated with an "epoxy" or other coating formulated for air conditioning systems located in coastal areas may be necessary.



Consult local building codes or ordinances for special installation requirements. When selecting a site to locate the chiller, consider the following:

- A minimum clearance of 60” on the front fan discharge, 12” on the rear air inlet and a 24” clearance is required on the service side.
- The chiller can be located out or indoors. If installed indoors there must be 4500 cfm of outdoor air changes circulated through the mechanical room to sufficiently operate the chiller. No ductwork can be connected to the chiller’s condenser or condenser fans.
- If a concrete slab is used, do not connect the slab directly to any building’s foundation or structure to prevent sound transmission.
- Locate the slab on a level surface that is above grade to prevent ground water from entering the chiller cabinet.

Stated Service Clearances

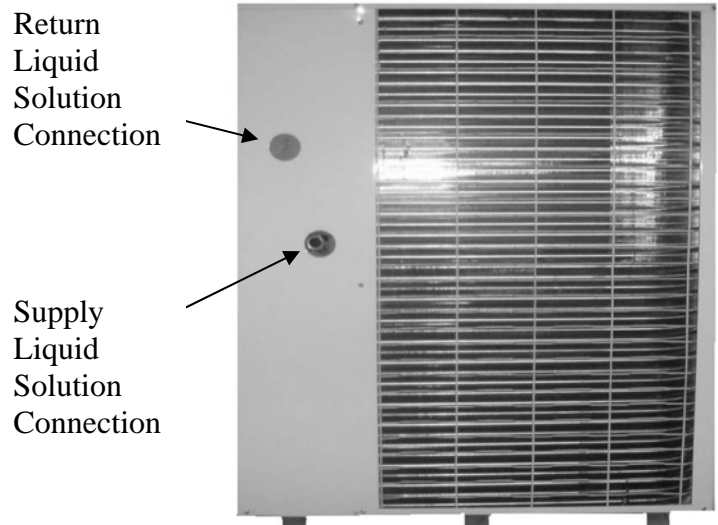
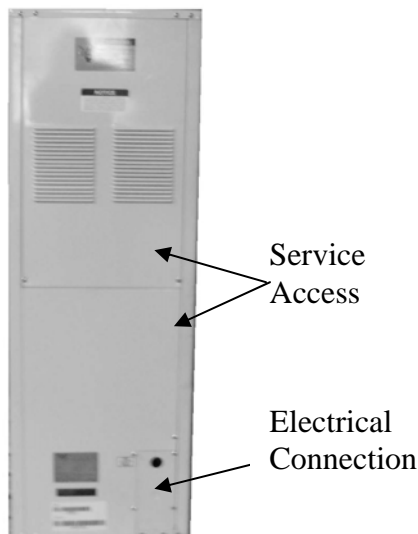
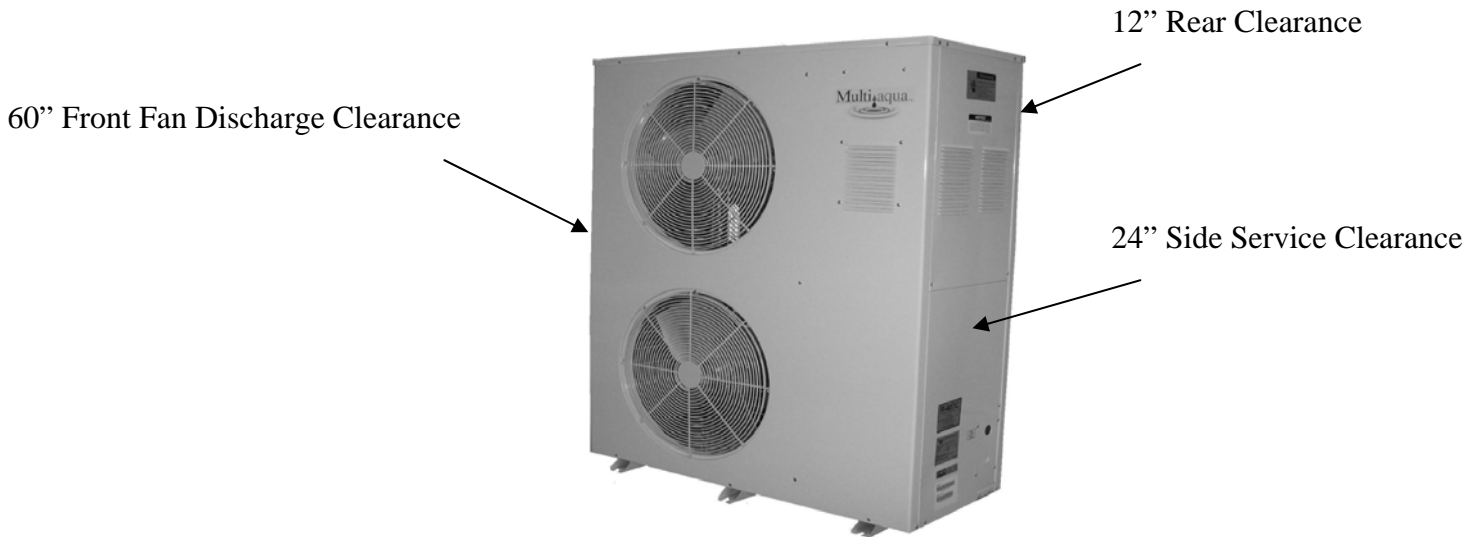

Description of Electrical Controls

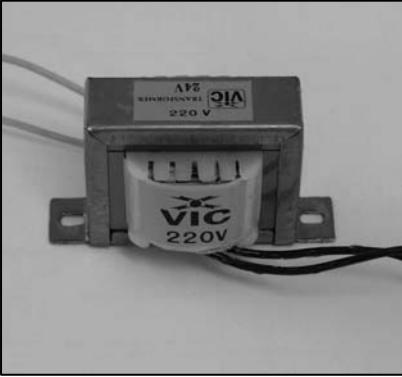

Control Transformer: The control transformer is rated at 24 vac, 40 va (1.6 amps @ 24vac)



Pump Bypass Timer: The pump bypass timer is a 24 vac, 3-wire control. When energized the timer will bypass the flow switch for 10 seconds (by creating a circuit to the pump relay), energizing the pump relay, allowing the pump to operate long enough to close the flow switch. In a normally operating system the flow switch will stay closed powering the pump relay in series with the low and high- pressure switches. Should the flow switch open, the timer can only be reset by opening and closing the chiller's line voltage disconnect.



Refrigerant System Timer: The refrigerant timer is a 24 vac, 5-minute delay on break, 20wire timer. The normally closed contacts of the timer energize the compressor contactor through the chilled solution control. When the chilled solution control contacts open, the timer delays by opening its contact for 5-minutes before resetting to the closed position.



High Pressure Switch: The high-pressure switch is an automatic reset control that senses compressor discharge line pressure. It opens at 400 PSIG and closes at 300 PSIG.

Description of Electrical Controls (continued)



Low Pressure Switch: The low-pressure switch is an automatic reset control that senses compressor suction line pressure. It opens at 40 PSIG and closes at 80 PSIG.

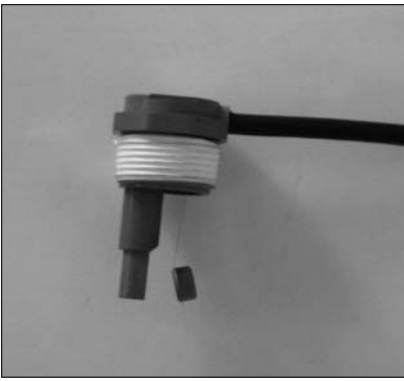

Flow Switch: The flow switch senses liquid solution flow. The paddle of the switch is inserted through a fitting into the pump discharge line. Liquid solution flow deflects the paddle closing the switch. The flow switch is position sensitive. The arrow ↑ on the switch must point in the direction of liquid solution flow.



Compressor Contactor: The compressor contactor energizes the compressor through the two or three normally open contacts. The contactor coil operates (closes the contacts) when energized by 24 vac.



Pump Relay / Contactor: The pump relay energizes the pump through a normally open contact. The pump relay coil operates (closes the contact) when energized by 24 vac.

Description of Electrical Controls (continued)



Liquid Solution Temperature Control: The liquid solution temperature control is an adjustable microprocessor based temperature control. This control receives temperature information from a thermistor located on the liquid solution supply line. A liquid crystal display continually indicates liquid solution temperature. The control is mounted inside the chiller cabinet.

Chiller Controls Sequence of Operation

When powered up the Multiaqua chiller system energizes the control transformer creating 24 vac control voltage.

First the pump bypass timer is energized and temporarily bypasses the flow switch, energizing the pump relay. The pump then starts to move liquid solution through the piping system (in a properly filled and air purged system). The movement of liquid solution from the pump discharge keeps the flow switch closed. After a 10 second delay the pump contact opens, connecting the flow switch in series with the high and low pressure switches. The pump will now run continually unless the power supply is interrupted, or the flow switch opens.

If the liquid solution temperature controller is calling for cooling the control circuit is routed through the short cycle timer and the three safety switches (the flow, high and low pressure switches) to the compressor contactor. This will energize the compressor(s) and condenser fan motors. The liquid solution controller will open at the user programmed set point, causing the refrigerant short cycle timer to open it's contact for 5 minutes as it delays before resetting to the closed position. This will de-energize the compressor. Power fluctuations will also initiate a 5 minute time delay. The 5 minute delay allows the refrigerant system a period for pressure equalization, protecting the compressor(s) from short cycling.

The chiller temperature controller utilizes a thermistor to monitor the liquid solution temperature change. The temperature is then compared to the set point and differential temperatures programmed into the control by the user. The set point is the liquid solution temperature which will cause the control switch to open. For example: The control set point is programmed at 44°F LWT with a 10°F differential, which opens the controller at 44°F LWT and closes at 54°F. The differential temperature is the number of degrees above set point temperature programmed into the controller. If liquid solution temperature falls to the set point, the controller cycles the compressors off.



Chillers are shipped with the control set point adjusted to 44°F LWT and a 10°F differential. Liquid solution temperature set point should not be set below 35°F.

SYSTEM FAULTS:

Flow Switch Opening: The flow switch is normally closed during pump operation. Should liquid solution flow be interrupted for any reason the control will open shutting down and locking out the chiller operation. The only exception to this is when power is first applied to the chiller and the pump bypass timer bypasses the flow switch for 10 seconds.



When the system is first filled with liquid solution and the pump is started, expect the system to cycle off on the flow switch, until all of the air is removed from the piping system. The system will have to be reset by opening and then closing the disconnect switch or circuit breaker powering the chiller.

Low Pressure Switch Opening: Should the compressor suction pressure go low enough (40 PSI) to open the low-pressure switch, the compressor and condenser fan motors will shut down. Check for a refrigerant leak, inoperative thermal expansion valve, low liquid solution control setting, low ambient operation, low liquid solution flow, etc.

High Pressure Switch Opening: Should the compressor discharge pressure go high enough to open the high-pressure switch, the compressor and condenser fan motors will shut down. Check for a dirty condenser coil, inoperable fan motor(s) or the recirculation of condenser air.

Refrigeration System Operation

The refrigeration system is a closed loop consisting of 1 compressor, single circuit heat exchanger (evaporator), metering device (TXV) and condenser coil. The refrigerant circulated is R407c. Hot gas is pumped from the compressors to the condenser coil where the two condenser fans pull cooler air across the coil condensing and sub cooling the refrigerant. The now liquid refrigerant flows through the liquid line to the thermal expansion valves, where the refrigerant pressure drops causing the refrigerant to boil at a much lower temperature (34-40°F). The refrigerant leaves the expansion valves and swirls through the plates of the heat exchanger absorbing heat from the circulating liquid solution.

The evaporator or heat exchanger is designed to operate with an 8-10°F superheat. The condenser is designed to condense the refrigerant and sub cool it to 10°F below condensing temperature.

Description Of Refrigerant Components



Scroll Compressor: All Multiaqua chillers feature Scroll compressors. Scroll technology ensures reliable high performance at a low sound level over a wide range of operating conditions.



Caution the top half of the scroll compressor operates at a temperature high enough to cause serious injury.

Description Of Refrigerant Components (continued)



Brazed Plate Heat Exchanger: The "Heat Exchanger" or evaporator is of a brazed copper and stainless steel design. Refrigerant and liquid solution is channeled through narrow openings between plates and flows in opposite directions. The counter flow design and fluid turbulence ensures maximum heat exchange at minimal pressure drop.



Thermal Expansion Valve: Multiaqua chillers are equipped with Thermal Expansion valves. The valves feature a liquid charged sensing bulb for consistent superheat at various load conditions.



Condenser Coil: The air-cooled condenser coil is of copper tube with aluminum fin construction. The coil is protected by a painted metal condenser grille.

Piping System Components



Supply Storage Tank: The supply storage tank must be used in the system with less than 25 gallons of liquid solution. The tank prevents rapid cycling of the compressors and acts as a reserve for chilled liquid solution.



Supply storage tank must be insulated in the field.

Part Number: WX202H (20 Gallon)
WX202H (42 Gallon)



Expansion Tank and Air Scoop: The Expansion Tank and Air Scoop assembly is used to compensate for the expansion and contraction of liquid in the system. The air scoop eliminates air entrance in the liquid solution.

Part Number: 1500/1"



Liquid Solution Bypass Valve: The liquid solution bypass valve relieves system pressure from the liquid solution supply to the return as system air handler control are cycled off.

Part Number: D146M1032- 3/4"
D146M1040- 1 1/4"



Motorized Valve: The air handler motorized valve controls the flow of liquid solution' to the systems air handlers. Each air handler in the system should have a motorized or solenoid valve.

Part Number: MZV524E-T 1/2" 2-Way Zone Valve
MZV525E-T 3/4" 2-Way Zone Valve
MZV526E-T 1" 2-Way Zone Valve
VT3212G13A020 1/2" 3-Way Zone Valve
VT3212G13A020 3/4" 3-Way Zone Valve

Composite Piping Layout and Design

Understanding the function and friction loss of each part of the piping system is important to the layout and successful installation of a chilled liquid solution system.

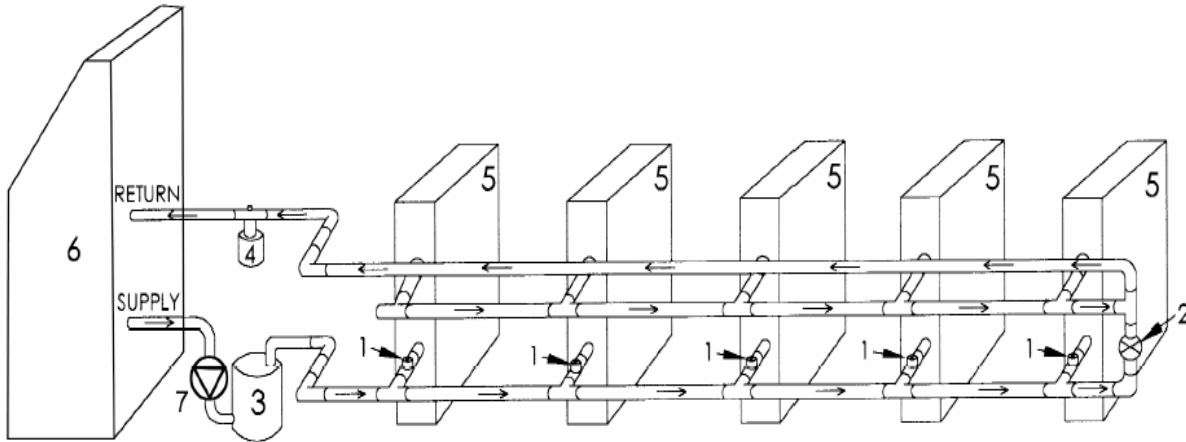

- 1- 2-Way Liquid Solution Control Valves
- 2- Bypass Valve
- 3- Storage Tank
- 4- Expansion Tank
- 5- Coil
- 6- Chiller
- 7- Pump

The circulation pump is the key performer in the piping system. The pump must circulate the liquid solution through the heat exchanger and piping system to the air handlers. Pumps are designed to deliver a flow rate measured in gallons per minute (GPM). The pump must be able to overcome the resistance to flow (pressure drop) imposed by the chiller components, piping system and air handlers while maintain the necessary flow rates in gallons per minute. Pump capacities in gallons per minute and pressure drop (feet of head) are listed in table 1.

Banked Chiller Configuration

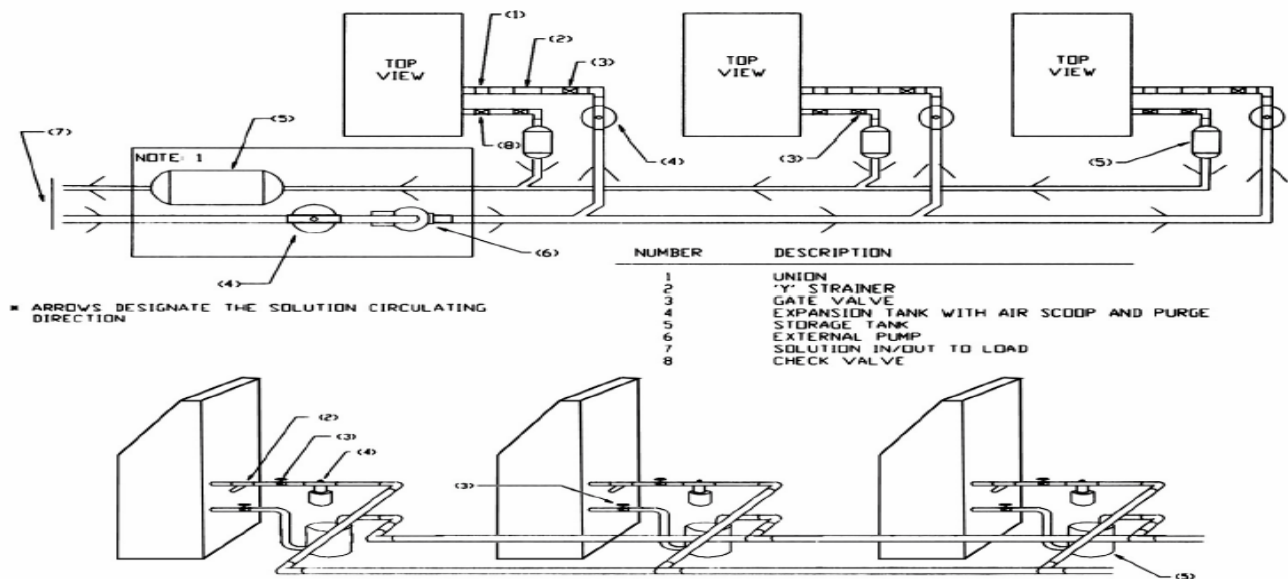

Notes:
Installing Multiaqua chillers in parallel is recommended.



An adjustable valve must be used to throttle the discharge liquid solution flow rate to appropriate levels based on capacity and glycol mix percentages.

	MAC036	MAC048	MAC060
Compressor	Copeland Scroll	Copeland Scroll	Copeland Scroll
Refrigerant	R407c	R407c	R407c
Heat Exchanger	Brazed Plate	Brazed late	Brazed Plate
Max.Head Pressure	50 ft	50 ft	50 ft
Max Flow rate	8.6 gpm	11.5 gpm	14.4 gpm
Min Flow Rate	5.5 gpm	6.5 gpm	9.0 gpm
Supply Water Temp	44°	44°	44°
Return Water Temp	55°	55°	55°
Min Solution Content	25 Gallons	25 Gallons	25 gallons
Expansion Tank Size	2 Gallons	2 Gallons	2 Gallons
Pump	0.5 HP	0.5 HP	0.5 HP
Water Connections	1" Supply & 1.25 Return	1" Supply & 1.25" Return	1"Supply & 1.25" Return
Internal Pressure Loss	1.77 ft of hd	1.68 ft of head	1.68 ft of head

Piping resistance or pressure drop is measured in feet of head. A foot of head is the amount of pressure drop imposed in lifting liquid solution one foot. Pumps in the Multiaqua system are designed to move rated liquid solution flow in GPMs.

Installation Notes:



Piping such as PEX, steel, copper or PVC can be used with the Multiaqua system. Check local building codes for material conformation. Care must be taken when using PVC as the presence of propylene glycol may destroy plastics. Pressure drop data for the selected piping material is readily available and should be used. Should the Multiaqua chiller be installed using existing steel (ferrous metal) piping system, dielectric fittings must be used at the chiller and air handler. The factory supplied wye strainer will capture particles of rust and sediment inherent with steel piping and should be checked and cleaned after initial start up and open a regular maintenance during the life of the system.



Any piping used to conduct liquid solution must be insulated in accordance with local and national mechanical codes. Information on insulation installation and application can be obtained from Armaflex web site at www.armaflex.com and Owens-Corning site at www.owenscorning.com/mechanical/pipe/. For future servicing of the chiller and air handlers, it is suggested that shutoff valves be installed at the chiller and air handler (s). If ball valves are used, they can double as balancing valve (s) in the supply piping at each air handler. Chiller shutoff valves should be attached at the chiller connections with unions.



The air handlers are to be controlled with electrically operated "slow-opening" solenoid valves, circulators or motorized zone valves as manufactured by Erie controls (www.eriecontrols.com/products/index.htm) A remote thermostat or air handler installed digital control operates the valves.



Bypass valves as shown in drawing 1, should be installed between the supply and the return chilled liquid solution supply pipes at a convenient location to the installation. The bypass valve operates to bypass liquid solution between the supply and return chilled liquid solution lines. In the event air handlers valves should shut down, the bypass valve is set to open up and bypass liquid solution between the supply and return lines, relieving pressure and eliminating the possibility of pump cavitations. To adjust the valve, run the system with one air handler solenoid actuated. De-energize the solenoid valve, (at this point no liquid solution will be flowing through the air handlers.) and adjust the bypass valve to relieve pressure between the supply and return piping.



Bleed ports will be factory installed on all Multiaqua air handlers. Bleed ports are opened to eliminate air trapped in the air handlers after filling the system with liquid solution and Propylene Glycol, and before operating the refrigerant compressor in the chiller.



The minimum liquid solution content in the chiller system, (piping, chiller, and air handlers), is 25 U.S. gallons. Estimate the system liquid solution content. Should the system have less than 50 gallons of liquid solution content, a chilled liquid solution storage tank must be installed. The tank stores enough chilled liquid solution to prevent frequent chiller compressor cycles at light load and prevents chilled liquid temperature swings at higher load conditions when the chiller compressor is waiting to cycle on the time delay control.



Propylene Glycol must be added to the water used in the system. Propylene helps prevent freeze-ups due to low ambient temperature conditions and low chilled liquid solution temperatures. In comparison to water, Propylene Glycol slightly lessens the temperature exchange in the chiller heat exchanger. However, that is offset by the increased flow of liquid solution through the piping system enabled by the Propylene Glycol. To determine the Propylene Glycol content for various ambient temperatures refer to table 6 page 72.



In no instance should a Multiaqua chiller be installed with less than 10% Propylene Glycol content in the piping system. Using less than the recommended Propylene Glycol percentage content voids equipment warranty.

Polypropylene Glycol System Content vs. Minimum Ambient Temperature



To not engage in cold ambient mitigation will result in the failure of components, property damage and void warranty.

Table 6

Propylene Glycol %	Water Flow	Capacity	Min. Ambient Temperature	GPM Adjustment = 100 % Capacity
10%	x 1.020	x .99	26°F	x 1.01
20%	x 1.028	x .98	18°F	x 1.03
30%	x 1.036	x .98	8°F	x 1.07
40%	x 1.048	x .97	-7°F	x 1.11
50%	x 1.057	x .96	-29°F	x 1.16



Ethylene Glycol is environmentally hazardous and not recommended. Inhibited Propylene Glycol (typical automotive coolant) is not to be used in a Multiagua Chiller under any circumstances. Dow Chemical's "Ambitrol" family of Glycol-based coolants of food grade Propylene Glycol is suggested. Information on Ambitrol is available from Dow at www.dow.com, search word "Ambitrol".

Expansion Tanks:

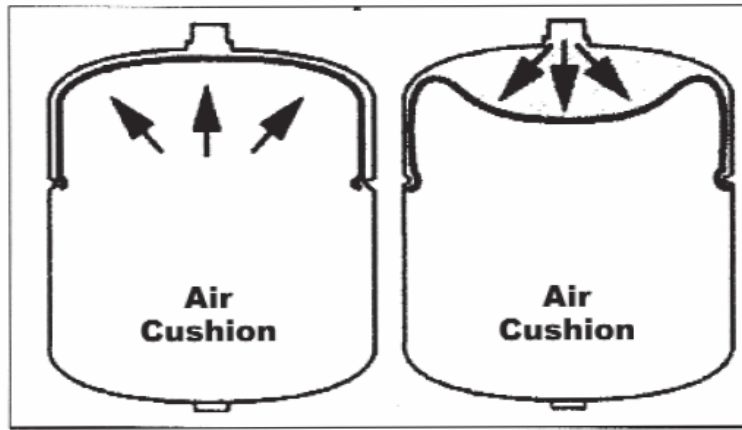

Liquid solution expansion and contraction within the closed system must be compensated for with an expansion tank. The expansion tank used with the Multiagua system, is a steel tank with a rubber bladder attached to it internally. There is air pressure on one side of the rubber bladder that keeps the bladder pushed against the sides of the tank before the system is filled with liquid solution (illustration above). As the liquid solution heats up the bladder, will be pushed further away from the tank walls, allowing for expansion and contracting as the liquid solution temperature changes. By flexing, the bladder controls the system pressure adjusting to temperature variations of the chilled liquid solution system.



It is critical that the expansion tank's air bladder pressure be less than the system solution pressure. Air pressure can be measured with an automotive tire gauge at the bicycle valve port on the expansion tank. Bleeding air out of the bladder or increasing the pressure with a bicycle pump will adjust pressure.



System must use a liquid solution storage tank if system volume is less than 50 U.S. gallons.

Filling System with Liquid Solution and Coolant (Propylene Glycol)



Concentrations of Propylene Glycol in excess of 50% will destroy o-rings in fittings and pump. Water should be added to the system first or a liquid solution diluted Propylene Glycol mix.



Before filling system with Propylene Glycol and water, pressure test the piping system with compressed air. Testing should be done at a minimum of 50 psi but no greater than 50 psi over the system's normal operating pressure. The system should hold air pressure for a minimum of one hour with no leakage.

System that contains 50 or more U.S. gallons should have a tee fitting with a stopcock installed in the return line close to the chiller. The stopcock can be opened and attached to a hose with a female X female hose fitting. In the open end of the hose section (1 -1.5 feet long) insert a funnel and pour into the system the diluted Propylene Glycol/liquid solution mixture or add water first and then the quantity of Propylene Glycol needed for minimum ambient protection (refer to Table 6). After adding the Propylene Glycol /water mixture, or liquid solution and then coolant proceed to add enough water to the system to achieve a 15 psi gauge pressure. To measure system pressure shut off the stopcock, remove hose and attach a water pressure gauge. Open the stopcock to read system pressure.

Systems that use the Chilled Liquid Solution Storage Tank should be filled at the tee/stopcock fitting in the outlet fitting of the storage tank. Fill the tanks with 10 gallons of water and with a funnel pour the calculated (refer to Table 6) amount of Propylene Glycol into the tank. The amount of Propylene Glycol added should be calculated to achieve minimum ambient protection. After adding Propylene Glycol, fill the system with enough liquid solution to bring system pressure to approximately 15 psi gauge pressure. To measure system pressure shut off the stopcock and attach a water pressure gauge. Open the stopcock to read system pressure.

Air Elimination

Since we have the system filled we must eliminate the air left in the system. Briefly open each bleed valve at the air handlers and allow trapped air to escape. This will eliminate much of the air left in the system. Next we will start the pump and continue bleeding air from the system. Be sure the chiller has line voltage available to it and set the chilled liquid solution control up to 100°F, which will ensure that only the pump runs at this point. The pump should now start and remain running. Should the pump stop at any time during this process it is an indication that the flow switch had air move across it allowing the circuit to be interrupted. Continue to bleed some air out of the system at the highest locations before resetting the pump bypass timer to get the pump running again. Open and close the power supply switch to the chiller to restart the pump. Continue bleeding air with the pump operating. You may have to start and re-start the pump a few times to complete air removal.



All piping systems should have a minimum of 10% Propylene Glycol in the system even in climates with non-freezing ambient temperatures.



Using less than the recommended Propylene Glycol percentage content voids equipment warranty.



Liquid solution control valves (solenoid or motorized valves) should be selected for low pressure drop. If a selected valve contributes to pushing your total head calculation to more than 50 feet of head, a larger valve may be needed to bring your total head below the maximum of 50 feet.

Liquid Solution Balancing:

Liquid solution balancing will require an accurate digital thermometer to measure return line liquid solution temperature at each air handler. Set the chilled liquid solution temperature control in the chiller at a normal operational temperature (44°F) and measure pump discharge temperature with the digital thermometer to check system solution temperature. After the chilled liquid solution temperature has lowered to the set point begin the balancing process. The system must be free of air and each air handler set at a temperature low enough to continue cooling operation (and liquid solution flow) during the balancing process. Begin by measuring the return line chilled liquid solution temperature of each air handler. Begin incrementally closing the supply line balance valve at the air handlers with the lowest return line chilled liquid solution temperature. Continue this process until each air handler has close to the same return line chilled liquid solution temperature.

MAC060-3 Ladder Wiring Diagram

380/460-3-50/60

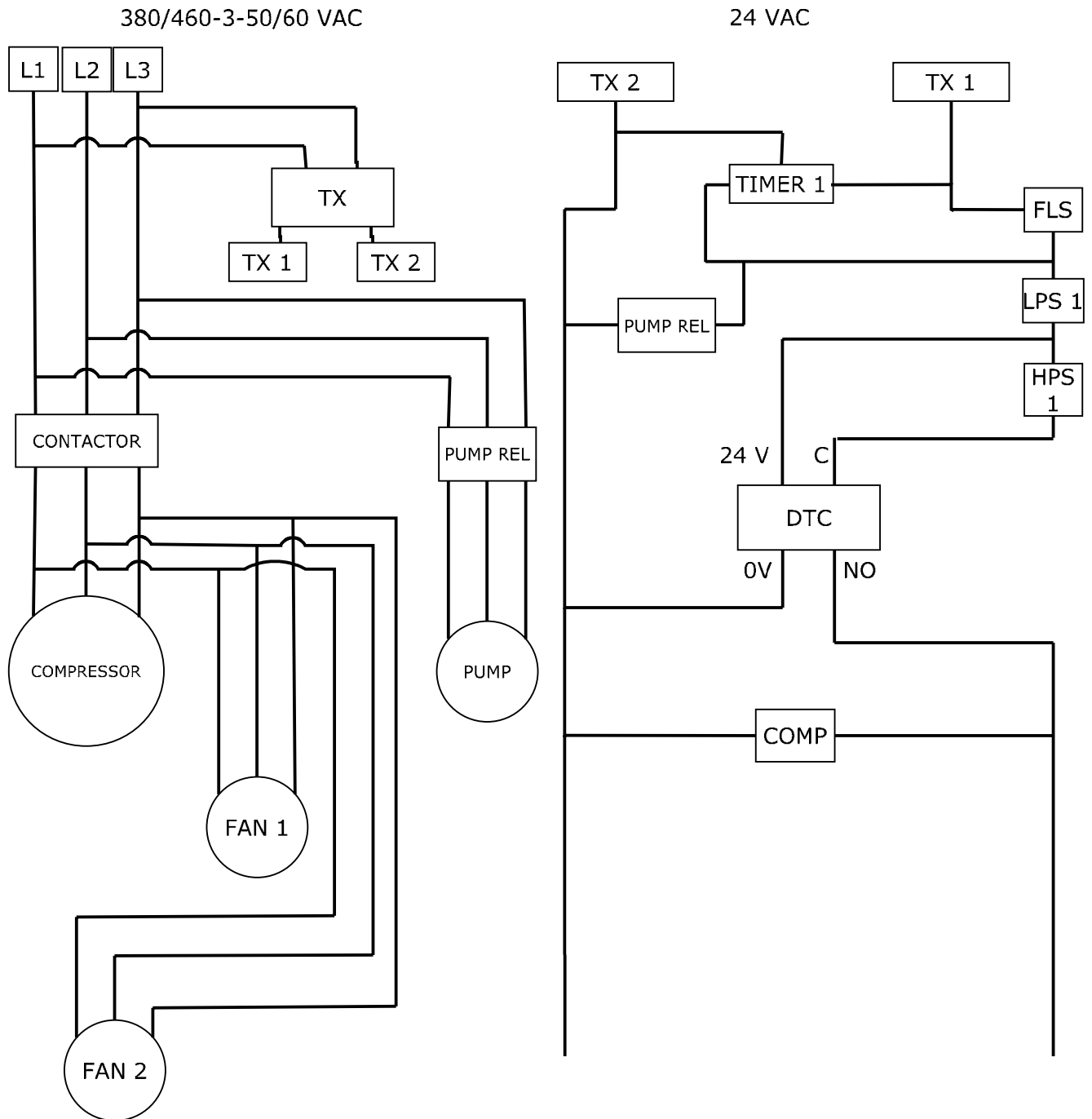

MAC060-3 Wiring Diagram

380/460-3-50/60

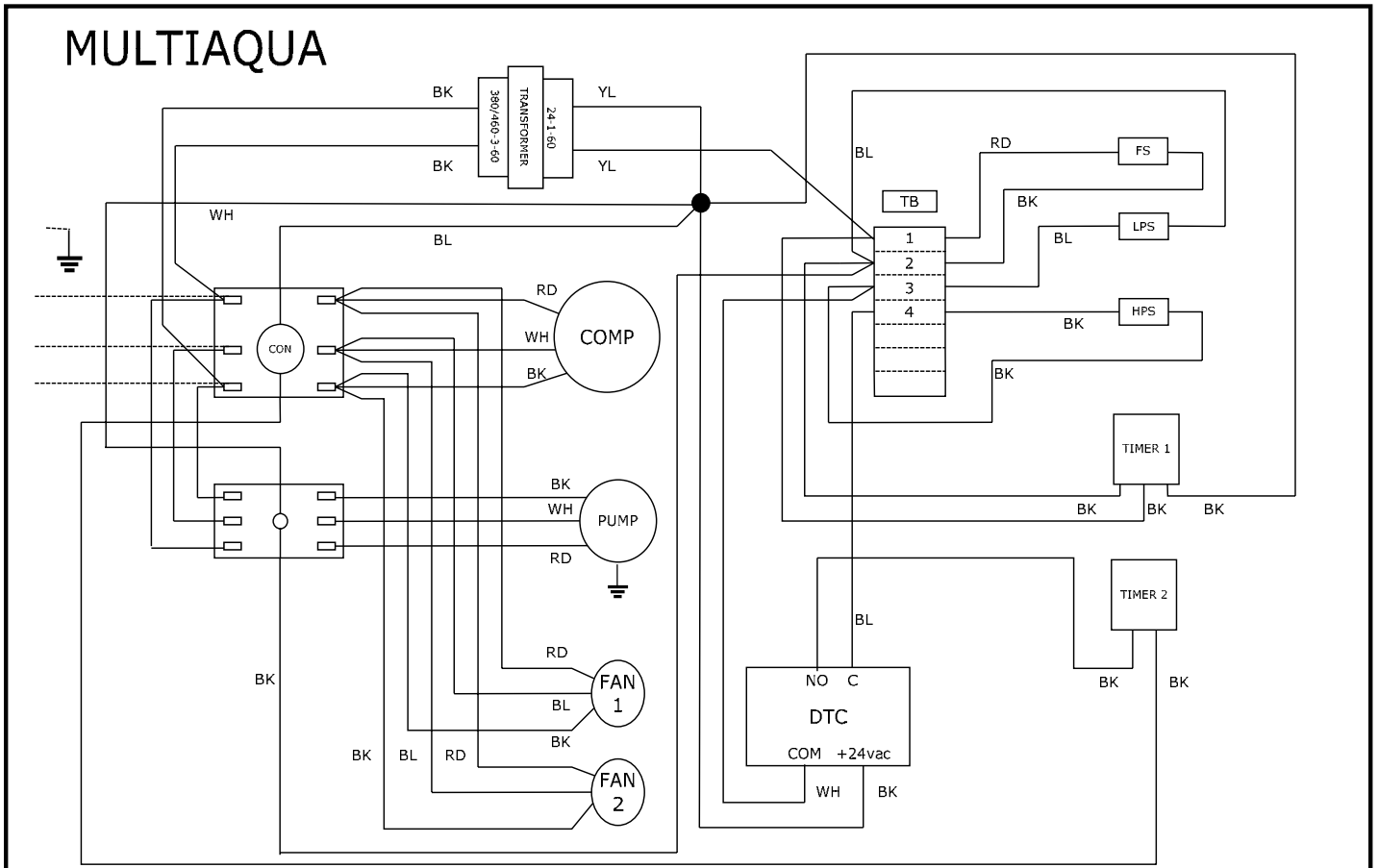

TITLE	MAC060 380/460-3ph	LEGEND:		NOTES:		
AUTHOR	kjg	————	FACTORY WIRING	LPS	LOW PRESSURE SWITCH	1. USE COPPER CONDUCTORS ONLY
DATE	06/28/07	-----	FIELD WIRING	HPS	HIGH PRESSURE SWITCH	2. BYPASS TIMER (TIMER1) SET FOR 10 SECONDS
REVISION	0607300021	DTC	DIGITAL TEMPERATURE CONTROLLER			3. DELAY ON TIMER (TIMER2) SET FOR 3 MINUTES
		TIMER 1	PUMP BYPASS TIMER			
		TIMER 2	REFRIGERANT SYSTEM TIMER			
		FS	FLOW SWITCH			
		CON	COMPRESSOR AND FAN CONTACTOR			

MAC060-3-L with Low Ambient Kit Wiring Diagram

380/460-3-50/60

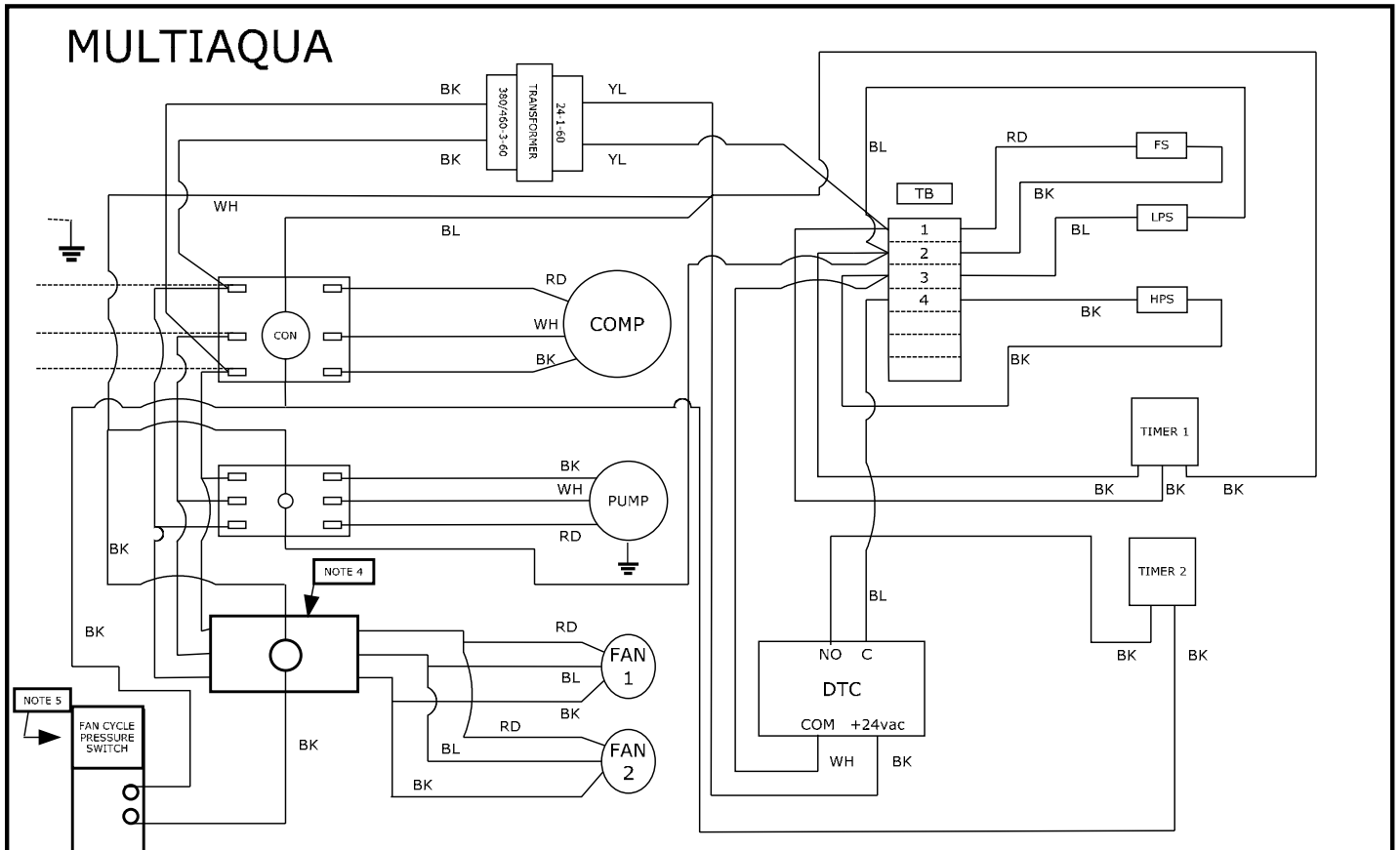

TITLE	MAC060-3 W/LAK	LEGEND:		NOTES:
AUTHOR	kjg	————	FACTORY WIRING	1. USE COPPER CONDUCTORS ONLY
DATE	08/30/07	-----	FIELD WIRING	2. BYPASS TIMER (TIMER1) SET FOR 10 SECONDS
REVISION	0807300035	DTC	DIGITAL TEMPERATURE CONTROLLER	3. DELAY ON TIMER (TIMER2) SET FOR 3 MINUTES
		TIMER 1	PUMP BYPASS TIMER	4. FAN CONTACTOR
		TIMER 2	REFRIGERANT SYSTEM TIMER	5. FAN CYCLE PRESSURE SWITCH
		FS	FLOW SWITCH	
		CON	COMPRESSOR AND FAN CONTACTOR	
		LPS	LOW PRESSURE SWITCH	
		HPS	HIGH PRESSURE SWITCH	

MAC036, 048 & 060-2 Ladder Wiring Diagram

208/230-3-50/60

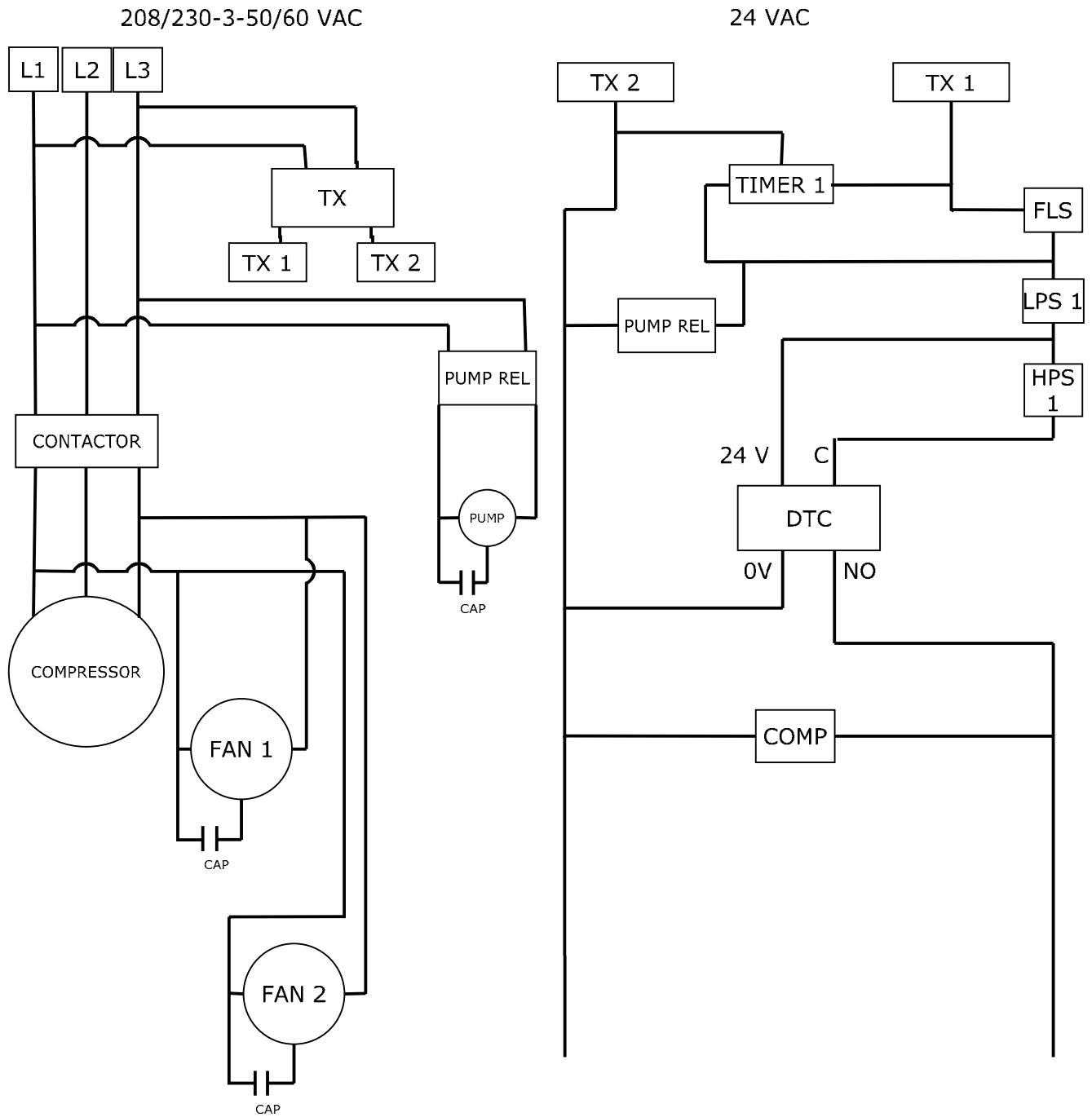

MAC036, 048 & 060-2 Wiring Diagram

208/230-3-50/60

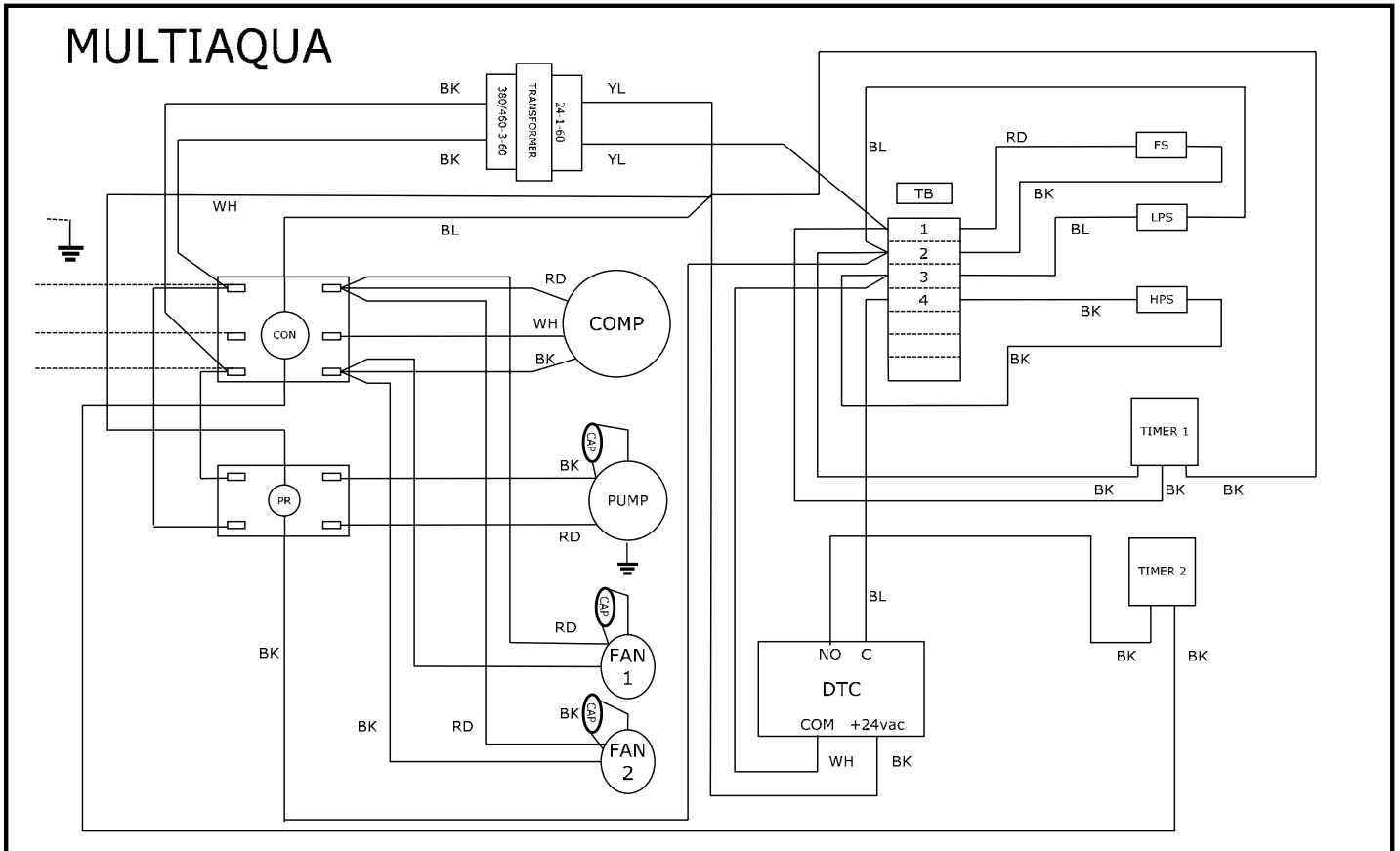

TITLE	MAC036,048,060-2	LEGEND:		NOTES:
AUTHOR	kjg	————	FACTORY WIRING	1. USE COPPER CONDUCTORS ONLY
DATE	08/31/07	-----	FIELD WIRING	2. BYPASS TIMER (TIMER1) SET FOR 10 SECONDS
REVISION	0807300036	DTC	DIGITAL TEMPERATURE CONTROLLER	3. DELAY ON TIMER (TIMER2) SET FOR 3 MINUTES
		TIMER 1	PUMP BYPASS TIMER	
		TIMER 2	REFRIGERANT SYSTEM TIMER	
		FS	FLOW SWITCH	
		CON	COMPRESSOR AND FAN CONTACTOR	
		LPS	LOW PRESSURE SWITCH	
		HPS	HIGH PRESSURE SWITCH	
		PR	PUMP RELAY	

MAC036, 048 & 060-2-L with Low Ambient Kit Wiring Diagram

208/230-3-50/60

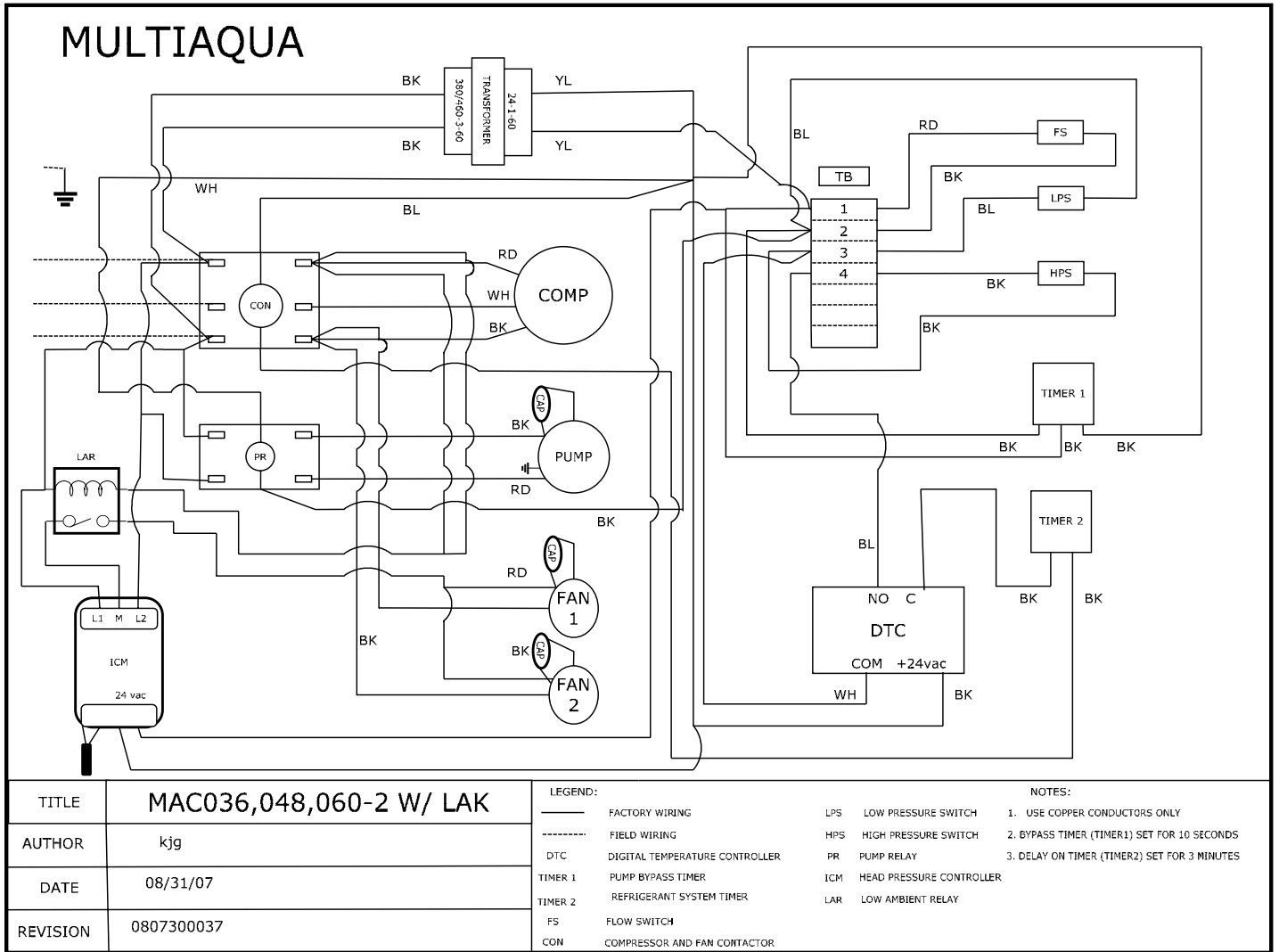

MAC036, 048 & 060-1 Ladder Wiring Diagram

208/230-1-50/60

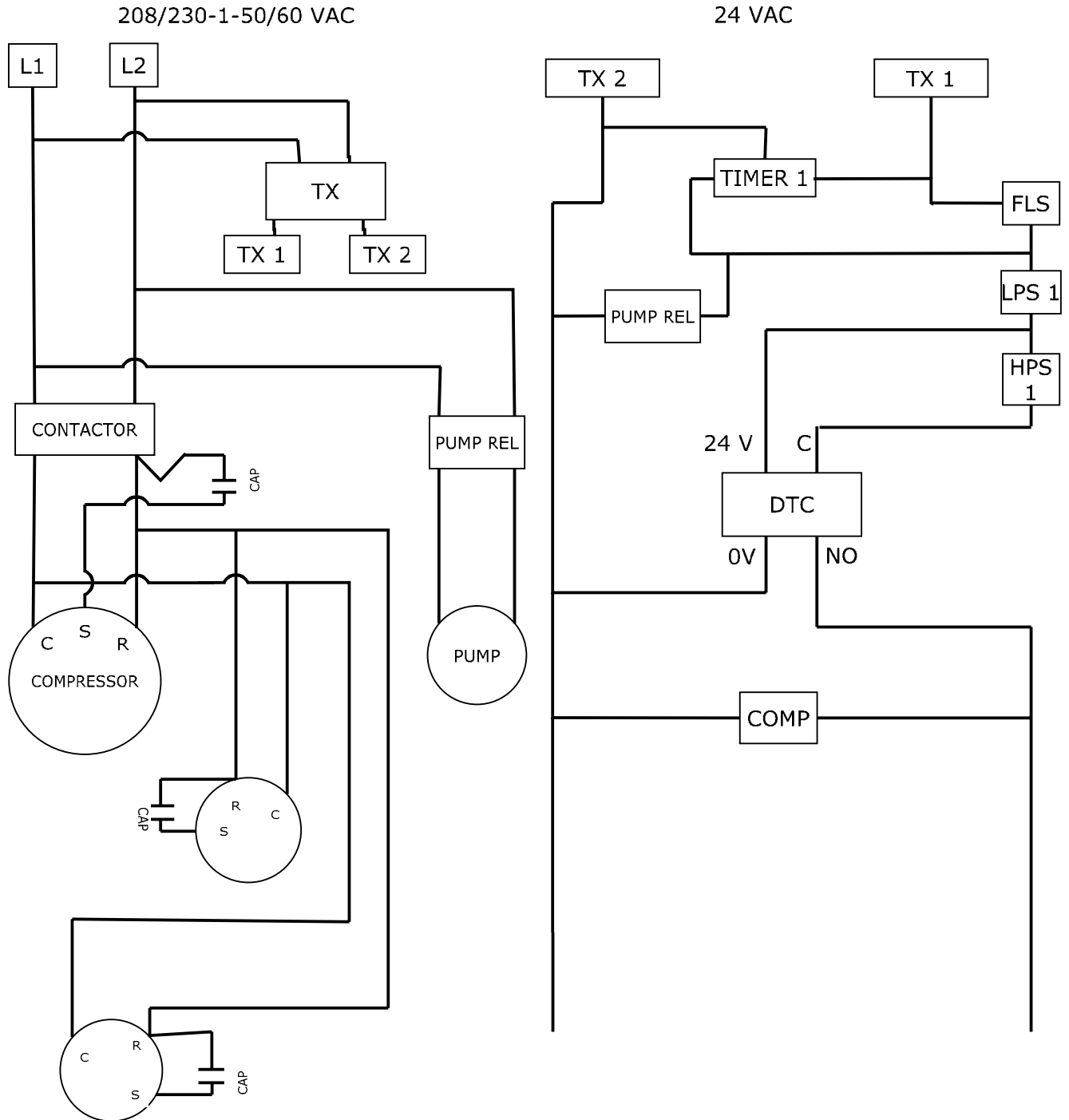

MAC036, 048 & 060-1 Wiring Diagram

208/230-1-50/60

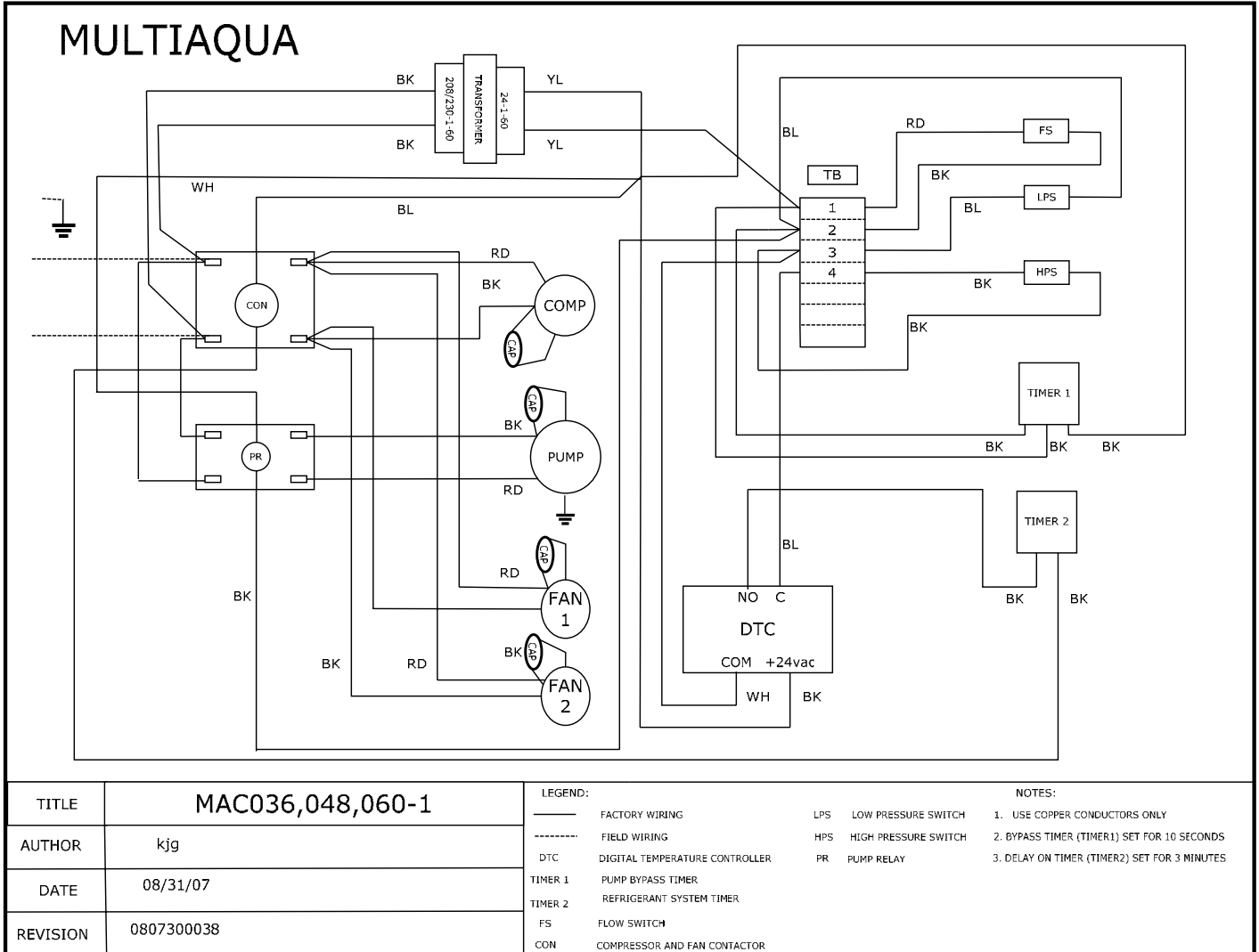

MAC036, 048 & 060-1-L with Low Ambient Kit Wiring Diagram

208/230-1-50/60

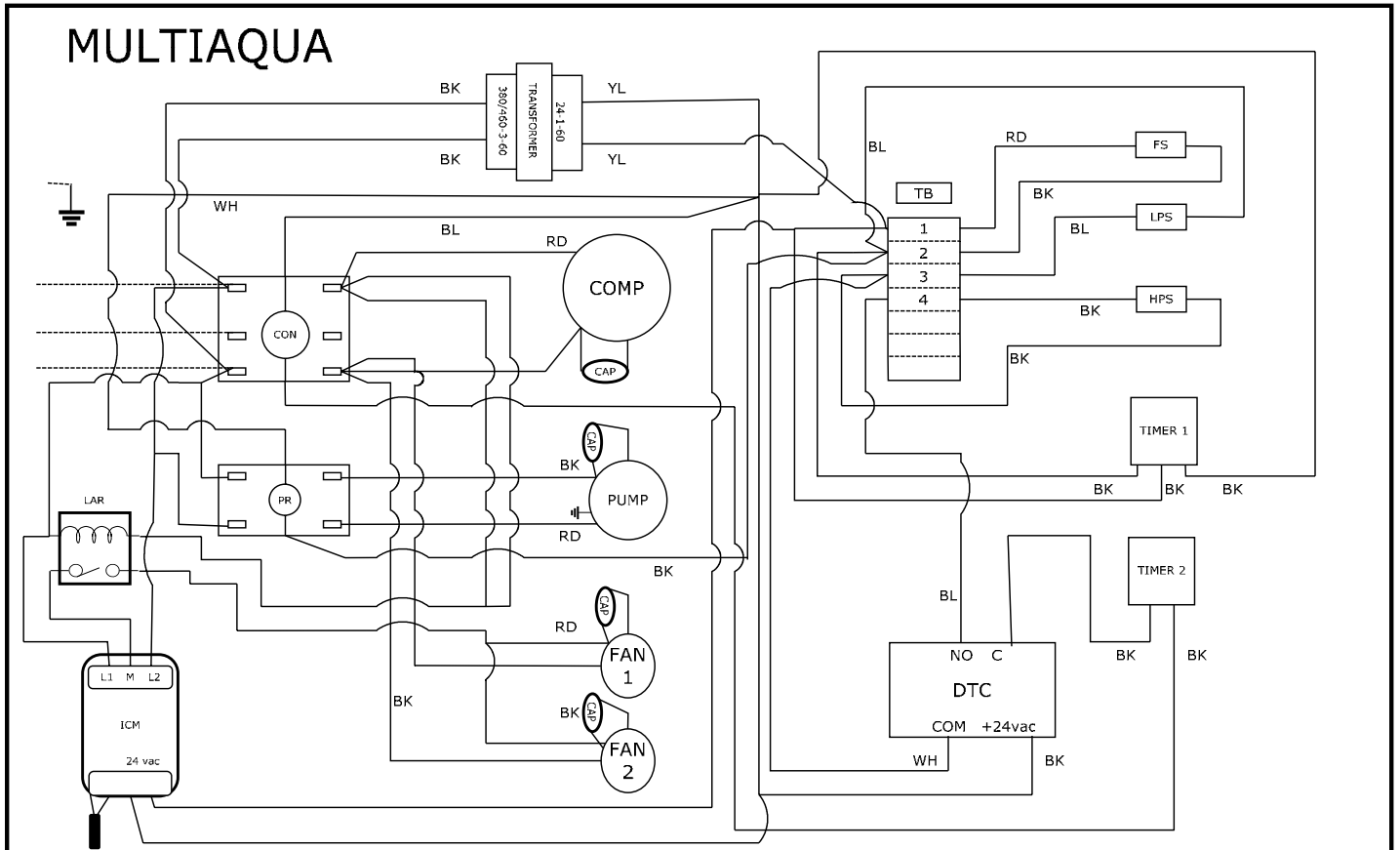

TITLE	MAC036,048,060-1 W/ LAK	LEGEND:		NOTES:
AUTHOR	kjg	————	FACTORY WIRING	1. USE COPPER CONDUCTORS ONLY
DATE	08/31/07	-----	FIELD WIRING	2. BYPASS TIMER (TIMER1) SET FOR 10 SECONDS
REVISION	0807300039	DTC	DIGITAL TEMPERATURE CONTROLLER	3. DELAY ON TIMER (TIMER2) SET FOR 3 MINUTES
		TIMER 1	PUMP BYPASS TIMER	
		TIMER 2	REFRIGERANT SYSTEM TIMER	
		FS	FLOW SWITCH	
		CON	COMPRESSOR AND FAN CONTACTOR	
		LPS	LOW PRESSURE SWITCH	
		HPS	HIGH PRESSURE SWITCH	
		PR	PUMP RELAY	
		ICM	HEAD PRESSURE CONTROLLER	
		LAR	LOW AMBIENT RELAY	

MAC036, 048 & 060 CERTIFIED DRAWING

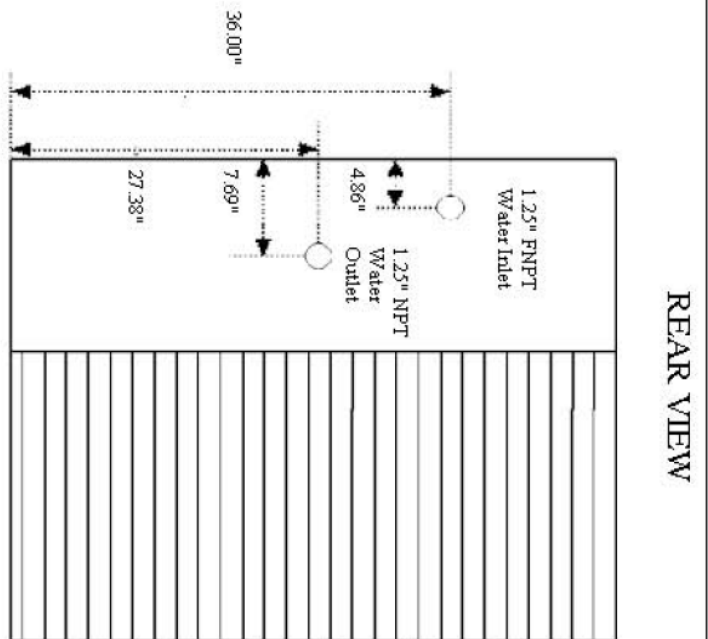
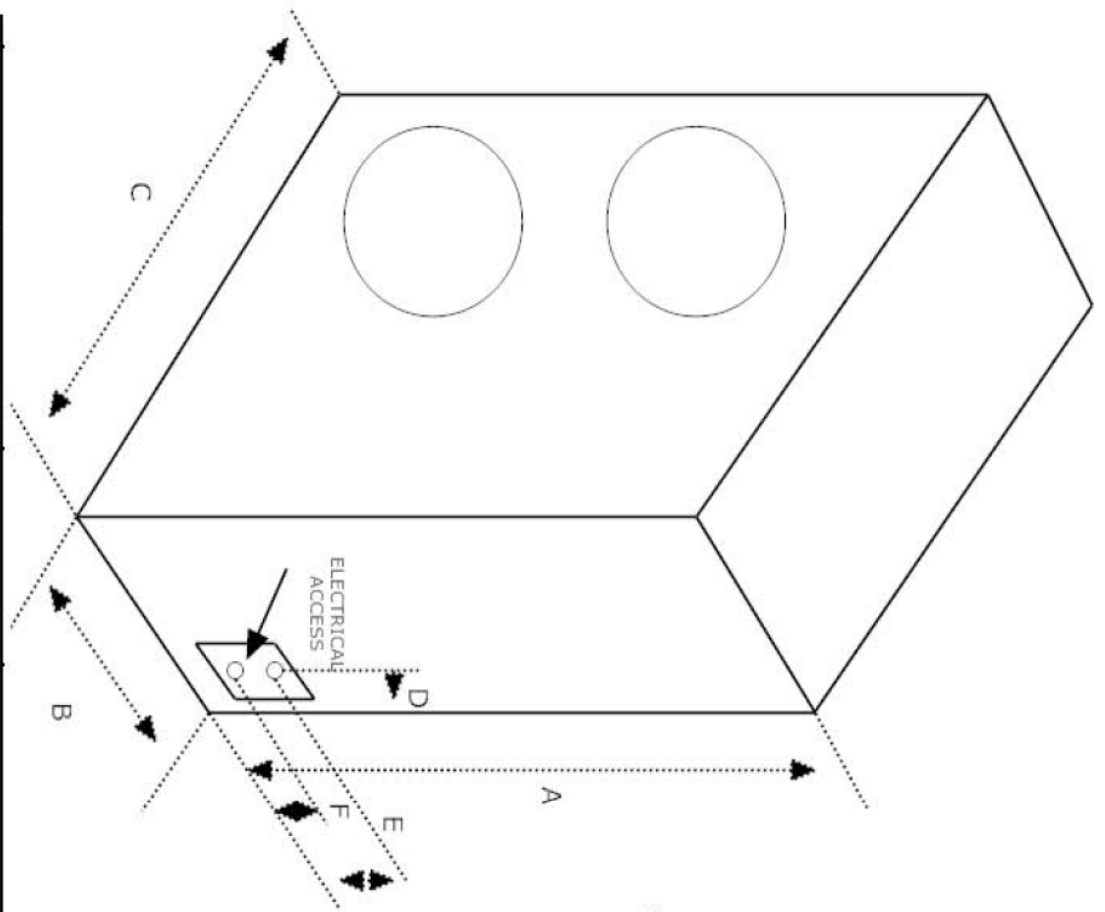

MAC036,048 & 060 Certified Drawing
Drawing # 0907400082

MAC036, 048 & 060						
MODEL	A	B	C	D	E	F
MAC036	49.62"	16.25"	39.75"	3.06"	8.94"	5.50"
MAC048	49.62"	16.25"	39.75"	3.06"	8.94"	5.50"
MAC060	49.62"	16.25"	39.75"	3.06"	8.94"	5.50"